

Smooth machine start-up thanks to wirelessly integrated remote I/O systems

Your I/O technology can be smoothly integrated in your usual engineering system with modules which adapt to your individual circumstances and are quick to get up and running.

Whether you opt for the IP 67 version directly on the panel or in the cabinet in an IP 20 housing, I/O systems from Weidmüller enable wireless integration in existing programming environments. Intelligent functions mean you are ready instantly.

With your practical equipment, our remote I/O systems optimise your machines and processes. Let's connect

IP 20



A.1 More Performance. Simplified.

u-remote.

IP 67



B.1 Modular Communication. Robust.

SAI aktiv.

More Performance. Simplified.

u-remote.

IP 20
A



Weidmüller u-remote – our innovative remote I/O concept with IP 20 which focuses purely on user benefits: tailored planning, faster installation, safer start-up, minimised downtimes. For considerably improved performance and greater productivity.



IP 20

IP 20	u-remote	A.2
	Introduction	A.6
	Field bus coupler	A.8
	Digital input modules	A.16
	Digital output modules	A.26
	Digital counter modules	A.36
	Pulse width modulation modules	A.40
	Analogue input modules	A.44
	Temperature modules	A.52
	Analogue output modules	A.56
	Power-feed modules	A.60
	Modules for functional safety	A.64
	Accessories	A.68
	System overview	A.72

More Performance. Simplified.

u-remote.

Weidmüller u-remote – the innovative remote I/O concept with IP 20 which focuses purely on user benefits: tailored planning, faster installation, safer start-up, minimised downtimes. For considerably improved performance and greater productivity. Reduce the size of your cabinets with u-remote, thanks to the narrow design and the need for fewer power-feed modules. Our u-remote technology also offers tool-free assembly, while the modular design and integrated web server speed up installation, both in the cabinet and machine. Status LEDs on the channel and each u-remote module enable reliable diagnosis and rapid service.

This and many other amazing ideas boost the availability of your machines and systems. And ensure smooth processes too. From planning to operation.

Our u-remote can do it all - More Performance. Simplified.

Speed things up with modularity

The modular structure of u-remote ensures rapid start-up and simple service. The compact design enables intuitive handling which reduces wiring mistakes and therefore lessens the start-up times for machines and systems. u-remote speeds up the replacement of electronics without the need to alter wiring during maintenance work, so improving system availability.

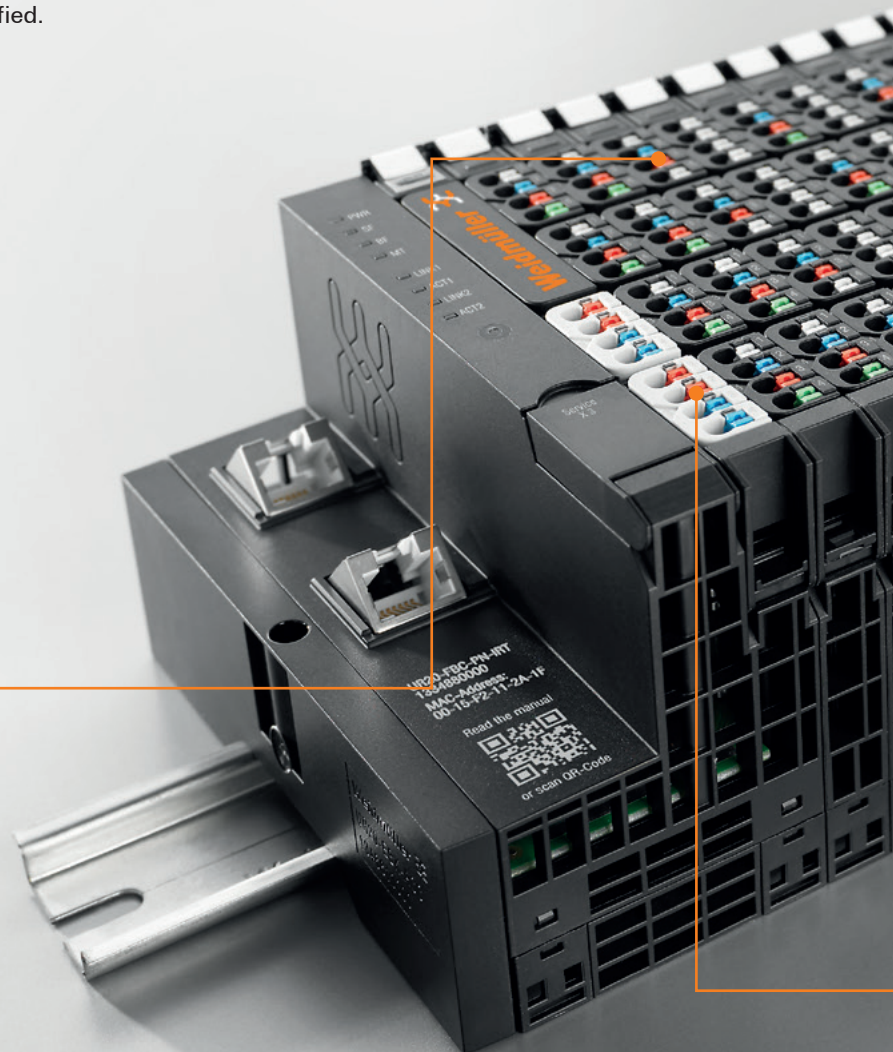

Improve system availability

The system simply runs on and on. The permanent base allows electronics to be replaced without interrupting communication, or the supply of voltage to your remote I/O system. A reliable solution for minimising machine downtime.

**Local and remote testing**

By starting up one section at a time, u-remote simplifies remote testing and its integrated web server capability speeds up maintenance work. It allows you to run diagnoses remotely using any standard browser and without having to install any software. You can also simulate inputs and force outputs, locally and with ease.

Plan for a smaller set-up

Now you can configure your cabinets one size smaller. With the narrow design (module width of 11.5 mm), not only does u-remote save space, it also delivers highest channel density and extremely flexible design options. For innovative and cost-saving solutions in small spaces.

**A single power supply is enough**

Keep your remote I/O station as small as possible and simplify your planning. u-remote has a 4 A supply path, which allows 64 I/O modules to be operated with just one power supply on the coupler.

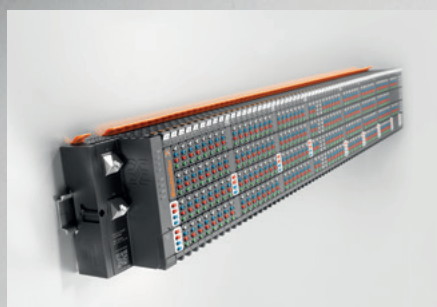
**Intelligently separated**

u-remote separates the supply for inputs and outputs using two 10 A current paths which are able to withstand high loads. High productivity translates into fewer power-feed modules and therefore more space and less planning. And your system can be quickly maintained while retaining full diagnostic capability, as inputs and outputs can be switched off independently of one another.



More Performance. Simplified. u-remote.

One glance and you can see everything going on

Clear assignment of status and diagnosis has never been this simple. With one LED on the channel and status displays on each module, you can easily see all you need on u-remote. The technician can see and rectify errors without delay. Indispensable benefits for a safe start-up and rapid system maintenance.



Extremely fast with huge power reserves

The u-remote has outstanding electronic performance, with the high-speed system bus achieving up to 256 DI/DOs in 20 μ s. u-remote offers an extremely fast response time and precise mapping of processes in the system, with up to 1024 I/O channels per station, as well as huge power reserves for future use.



Keeping it simple

The u-remote modules can be released without any tools and their sequence can be changed. For faster machine maintenance and simple system modification.

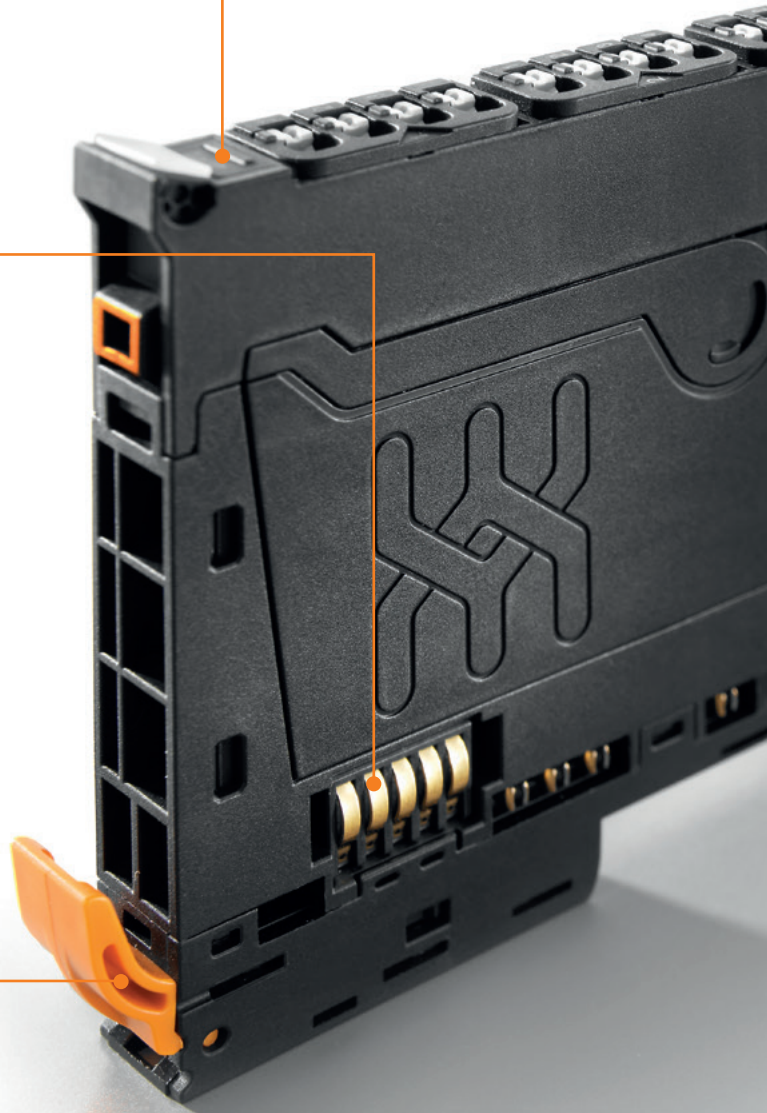

One row with no mistakes

The clearly structured single-row connection strip assists with assignment to the circuit diagrams. When working to tight deadlines, this prevents wiring mistakes and problems during service work.

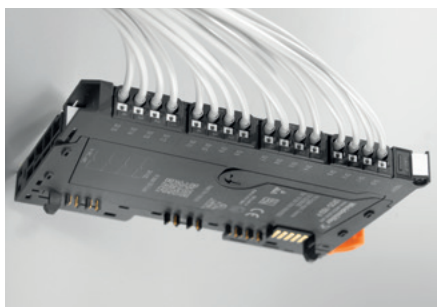
**Direct insertion – direct savings**

u-remote is equipped with "PUSH IN" direct connection technology. The conductor with wire end ferrule is simply inserted in the clamping unit until the stop is reached – job done! This technology delivers time savings of up to 50 percent, compared to conventional wire-connection methods, and without security losses on safety.

**Simply plug and go**

The plug-in connection level allows sensors and actuators to be connected with pre-assembled cables. This means improved time benefits, better handling, and minimises the number of mistakes in system wiring.

**Focus on reliability**

u-remote remains stable in the event of fluctuating temperatures. It is designed for use in temperatures of between $-20\text{ }^{\circ}\text{C}$ and $+60\text{ }^{\circ}\text{C}$ without restrictions on function, which is not only great for safety, but the system's life expectancy too.

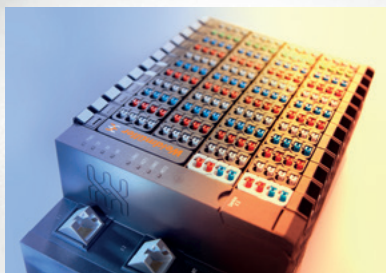

More Performance. Simplified. u-remote.

IP 20

A



Let's connect.

IP 20

u-remote from Weidmüller is the reliable interface between field bus and field level in automation. The modular system is based on various components: a field bus coupler, up to 64 I/O modules, optional power-feed modules and a wealth of accessories, such as markers and terminating elements.

The field bus coupler is the central link between the various field bus standards and the u-remote system bus. At the same time, up to 64 I/O modules are supplied via its integrated power contacts. The well-engineered technology of the connection system enables 2 x 10 A to be supplied for the input and output modules and the system voltage to be fully supplied through the field bus coupler.

Every field bus coupler provides direct access to the u-remote system via a web server without additional software having to be installed. This means that the system can be parameterised and its configuration checked. Inputs and outputs can also be checked or influenced. The connection may take the form of an Ethernet-based field bus or micro USB.

The u-remote field bus couplers are integrated in the standard simple manner. The corresponding development environments of the control systems and the device description files available online, e.g. GSD, ESD or XML, can be used to easily perform the necessary settings.

The modularly structured I/O modules are unique in that they allow the sensor and actuator wiring to be designed in both a robust and plug-in manner. This allows the electronics to be replaced at any time even with permanent wiring without downstream I/O module operations being affected. This achieves an invaluable time saving, in terms of both wiring inaccessible cabinets and rapidly replacing sensors. Thanks to the "PUSH IN" technology for up to 1.5 mm², in their narrowest form of 11.5 mm, the modularly structured u-remote I/O modules can be used for all sensor and actuator connections with a very high connection density. A clear status and diagnosis display on the connection also ensures rapid and precise checks for individual sensors and actuators.



PROFIBUS field bus coupler

DP-V1; Web server tool; Sub-D connection



IP 20
A

In automation technology, the PROFIBUS-DP standard enables the controlled incorporation of sensors and actuators via one central control unit. The UR20-FBC-PB-DP field bus coupler is a PROFIBUS-DP-V1 participant certified by the Profibus user organisation. With options for connecting up to 64 u-remote participants, it serves as the head module for the u-remote system bus. The PROFIBUS-DP coupler has a Sub-D plug-in connector and supports all services according to the DP-V1 specification. Two rotary coding switches are used to address individual PROFIBUS participants.

The coupler can be activated with a system-independent web server application via the USB service interface. All information, such as diagnoses, status values and parameters, can therefore be read out. All connected inputs can also be simulated or outputs set. The initial system power supply is already integrated in the field bus coupler. Power is supplied via two 4-pin connectors, separated into the input and output current paths.

Since the PROFIBUS-DP products from Weidmüller make full use of all the latest technological possibilities, such as GSD files and diagnosis messages, they actively support your application in the most important tasks – from engineering and commissioning fault diagnosis.

More Performance. Simplified.

Block diagram UR20-FBC-PB-DP

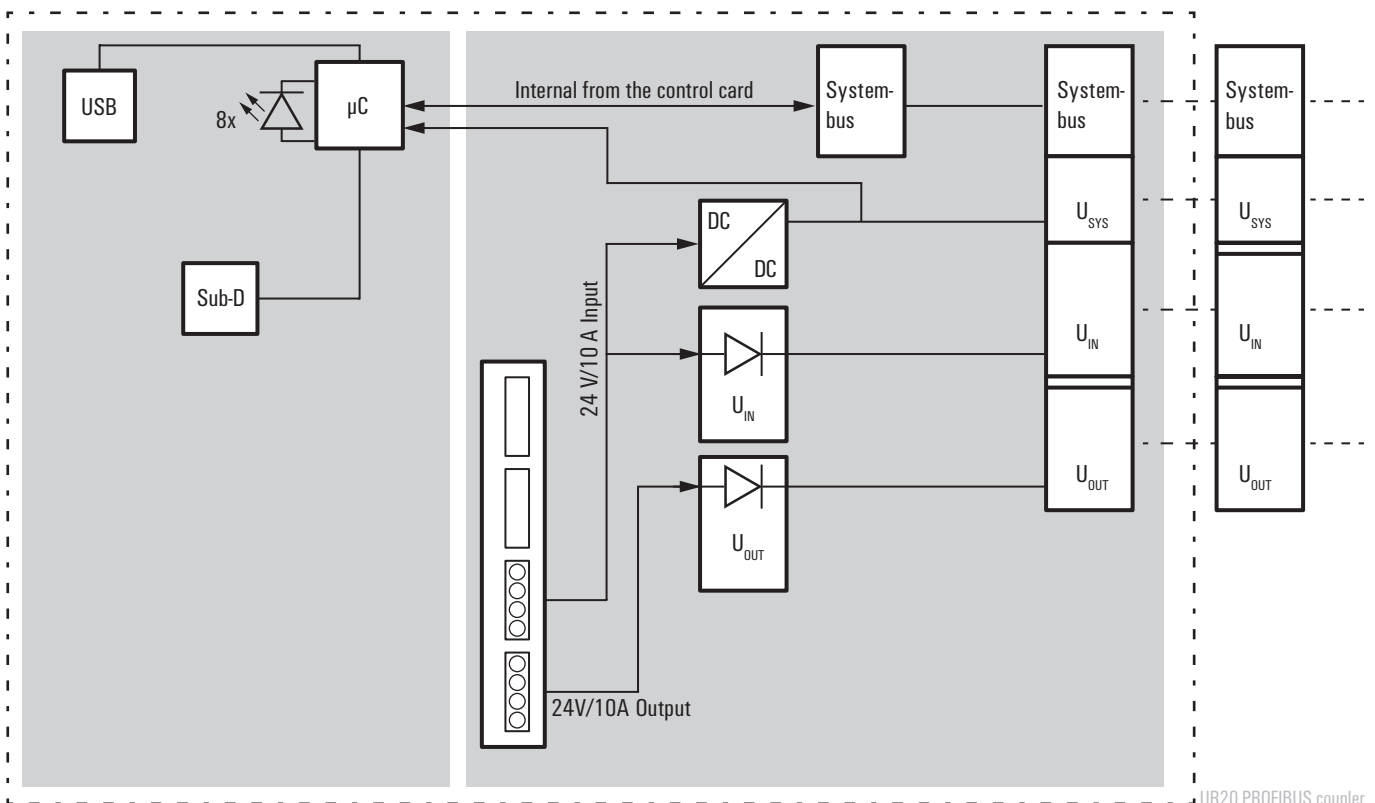

UR20 PROFIBUS coupler

PROFIBUS

- 2 x 10 A current paths
- Address can be set using rotary switch
- Web server
- System supply of 64 I/O modules
- Temperature range -20... +60 °C
- PROFIBUS DP-V1 up to 12 MBaud

UR20-FBC-PB-DP



Technical data

System data	
Connection	9-pin SUB-D connector
Field bus protocol	PROFIBUS DP-V1
Process data	488 Bytes
Parameter data	244 Bytes
Diagnostic data	244 Bytes
Max. number of I/O modules	64
Configuration interface	USB 2.0
Transmission rate of field bus	12 Mbit/s
Transmission speed of u-remote system bus	48 Mbit/s
Supply	
Supply voltage for system and inputs	24 V DC +20 % / -15 %
Supply voltage for outputs	24 V DC +20 % / -15 %
Feed current for input modules, max.	10 A
Feed current for output modules, max.	10 A
Current consumption (I _N in power segment of field bus coupler), typ.	100 mA
General data	
Weight	220 g
Dimensions (H/W/D)	120 mm (with catch lever 128 mm) x 52 mm x 76 mm
Note	
Download of GSD-file on www.weidmueller.com	

9-pin SUB-D connector		
PROFIBUS DP-V1		
488 Bytes		
244 Bytes		
244 Bytes		
64		
USB 2.0		
12 Mbit/s		
48 Mbit/s		
24 V DC +20 % / -15 %		
24 V DC +20 % / -15 %		
10 A		
10 A		
100 mA		
220 g		
120 mm (with catch lever 128 mm) x 52 mm x 76 mm		
Download of GSD-file on www.weidmueller.com		

Ordering data

Module variants	
Field bus coupler, PROFIBUS DP-V1	
Note	

Type	Qty.	Order No.
UR20-FBC-PB-DP	1	1334870000
A termination kit (UR20-EBK-ACC) is included in the coupler package		

Accessories

Coding elements		
Termination kit		
Swivel marker		
Connection marker for pusher custom printing		
Connection marker for pusher neutral		
Module marker for custom printing		
Module marker for neutral		
Thermotransfer version (Material: Polyester)		
Thermotransfer version (Material: Polyester)		
Paper version for Laserprinter		
Replacement parts		
Plug-in connector unit		
Note		

Type	Qty.	Order No.
KOSM BHZ5.00	100	1483050000
UR20-EBK-ACC	5	1346610000
UR20-SM-ACC	20	1339920000
PM 2.7/2.6 MC SDRVPE	192	1323700000
PM 2.7/2.6 MC NE WS	960	1323710000
DEK 5/8-11.5 MC SDR	100	1341610000
DEK 5/8-11.5 MC NE WS	500	1341630000
THM UR20 GE * ¹⁾	1	1429910000
THM UR20 WS * ¹⁾	1	1429420000
ESD UR20 DIN A4 WS * ²⁾	10	1429430000
UR20-PK-1334870000-SP	5	1361520000
* ¹⁾ 1 roll = 1000 label = 1 Qty. * ²⁾ 1 sheet = 60 label = 1 Qty.		

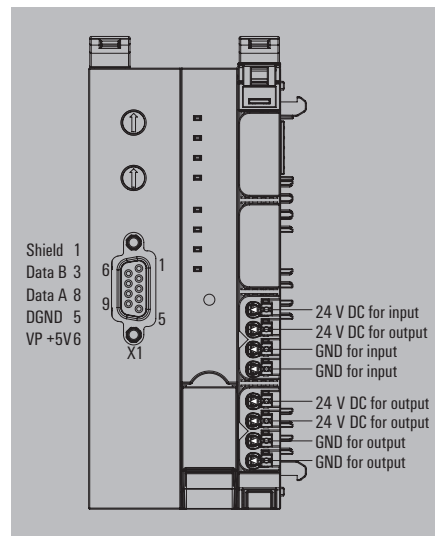

Product standard	IEC 61131-2
EMC	EN 61000
ATEX	EN 60079
UL	UL 508



Let's connect.

PROFINET field bus coupler

Web server tool;
two RJ45 ports; 100 Mbit/s

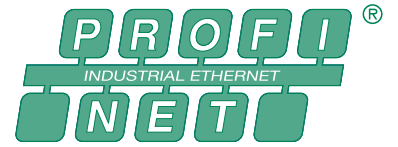

IP 20
A

PROFINET is gaining in importance as a rapidly growing Industrial Ethernet Standard. By supporting real-time functionality (RT) and isochronous real-time functionality (IRT), the technology complies with modern system and application requirements to a large extent. The UR20-FBC-PN-IRT field bus coupler is a PROFINET-IRT participant certified by the PROFIBUS user organisation. It is able to connect up to 64 u-remote participants and two Ethernet ports with integrated switch to implement a line network structure.

The coupler can be activated with a system-independent web server application via the USB service interface or the Ethernet ports. All information, such as diagnoses, status values and parameters, can therefore be read out. All connected inputs can also be simulated or outputs set. The initial system power supply is already integrated in the field bus coupler. Power is supplied via two 4-pin connectors, separated into the input and output current paths.

Since the PROFIBUS products from Weidmüller make full use of all the latest technological possibilities, such as GSD files and diagnosis messages, they actively support your application in the most important tasks – from engineering and commissioning to faults.

More Performance. Simplified.

Block diagram UR20-FBC-PN-IRT

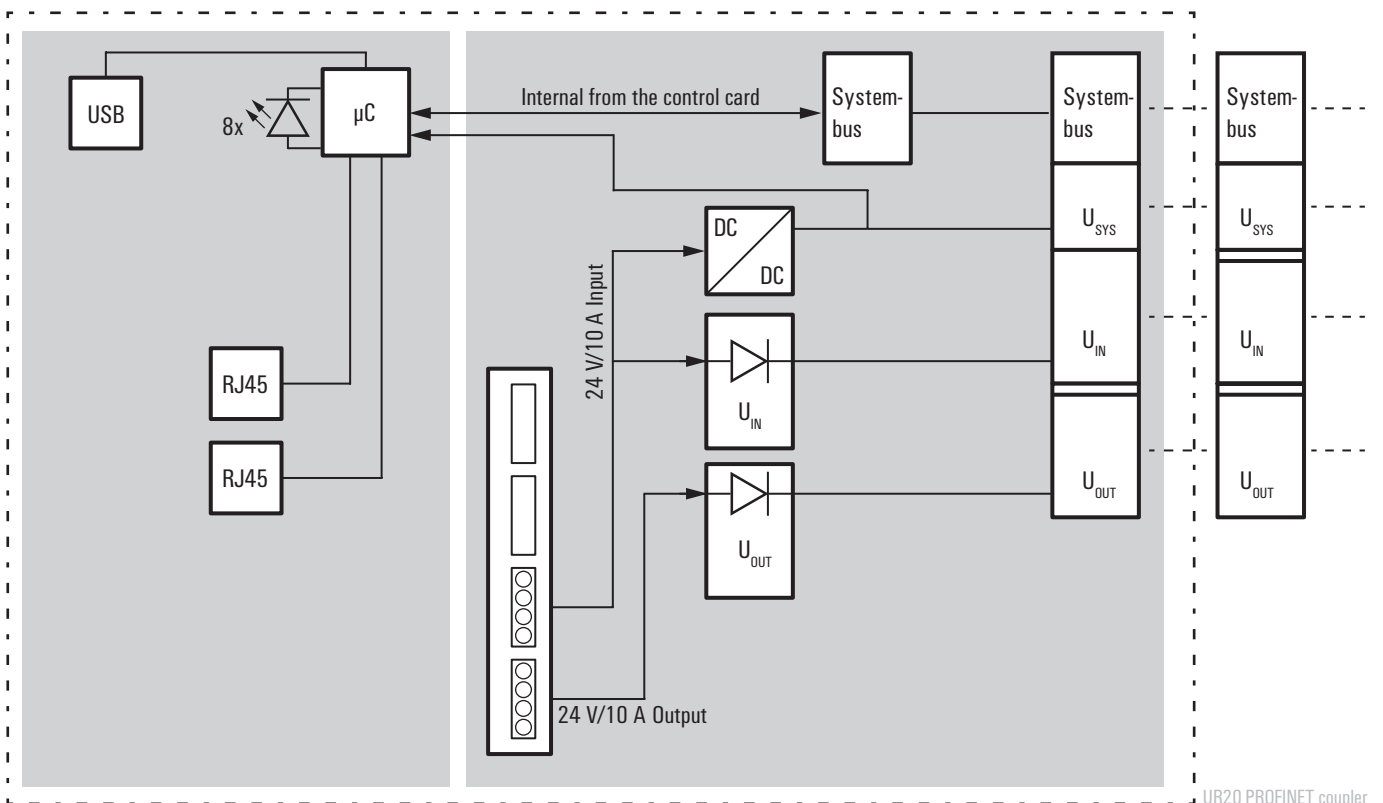

UR20 PROFINET coupler

PROFINET

- 2 x 10 A current paths
- Web server
- System supply of 64 I/O modules
- Temperature range -20... +60 °C
- PROFINET IRT/RT capable
- PROFINET diagnosis
- LLDP - Neighborhood detection

UR20-FBC-PN-IRT



Technical data

System data	
Connection	2 x RJ-45
Field bus protocol	PROFINET IRT
Process data	1.024 Bytes
Parameter data	1.485 Bytes
Diagnostic data	1.485 Bytes
Fast startup	yes
Max. number of I/O modules	64
Configuration interface	USB 2.0
Transmission rate of field bus	100 Mbit/s
Transmission speed of u-remote system bus	48 Mbit/s
Supply	
Supply voltage for system and inputs	24 V DC +20 % / -15 %
Supply voltage for outputs	24 V DC +20 % / -15 %
Feed current for input modules, max.	10 A
Feed current for output modules, max.	10 A
Current consumption (I _N in power segment of field bus coupler), typ.	116 mA
General data	
Weight	220 g
Dimensions (H/W/D)	120 mm (with catch lever 128 mm) x 52 mm x 76 mm
Note	
Download of GSD-file on www.weidmueller.com	

Ordering data

Module variants	
Field bus coupler, PROFINET IRT	
Note	

Type	Qty.	Order No.
UR20-FBC-PN-IRT	1	1334880000
A termination kit (UR20-EBK-ACC) is included in the coupler package		

Accessories

Coding elements	
Termination kit	
Swivel marker	
Connection marker for pusher custom printing	
Connection marker for pusher neutral	
Module marker for custom printing	
Module marker for neutral	
Thermotransfer version (Material: Polyester)	
Thermotransfer version (Material: Polyester)	
Paper version for Laserprinter	
Replacement parts	
Plug-in connector unit	
Note	

Type	Qty.	Order No.
KOSM BHZ5.00	100	1483050000
UR20-EBK-ACC	5	1346610000
UR20-SM-ACC	20	1339920000
PM 2.7/2.6 MC SDR	192	1323700000
PM 2.7/2.6 MC NE WS	960	1323710000
DEK 5/8-11.5 MC SDR	100	1341610000
DEK 5/8-11.5 MC NE WS	500	1341630000
THM UR20 GE * ¹⁾	1	1429910000
THM UR20 WS * ¹⁾	1	1429420000
ESO UR20 DIN A4 WS * ²⁾	10	1429430000
UR20-PK-1334880000-SP	5	1484120000
* ¹⁾ 1 roll = 1000 label = 1 Qty.		
* ²⁾ 1 sheet = 60 label = 1 Qty.		

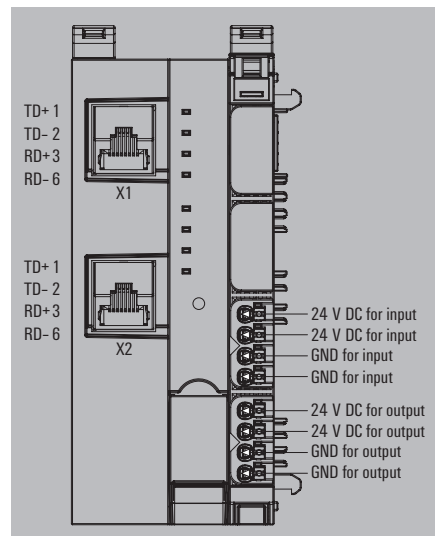

Product standard	IEC 61131-2
EMC	EN 61000
ATEX	EN 60079
UL	UL 508



Let's connect.

EtherCAT field bus coupler

Web server tool;
two RJ45 ports; 10/100 Mbit/s



IP 20
A

EtherCAT is a popular field bus standard for systems with stringent time requirements. The UR20-FBC-EC field bus coupler is an EtherCAT participant certified by the EtherCAT Technology Group. With options for connecting up to 64 u-remote participants, it serves as the head module for the u-remote system bus. The EtherCAT coupler has two Ethernet ports with integrated switch for implementing a line network structure.

The coupler can be activated with a system-independent web server application via the USB service interface or the Ethernet ports. All information, such as diagnoses, status values and parameters, can therefore be read out. All connected inputs can also be simulated or outputs set. The system's initial power supply is already integrated in the field bus coupler. Power is supplied via two 4-pin connectors, separated into the input and output current paths.

Since the EtherCAT products from Weidmüller make full use of all the latest technological possibilities, such as use of XML files, they actively support your application in the most important tasks – from engineering and commissioning to fault diagnosis.

More Performance. Simplified.

Block diagram UR20-FBC-EC

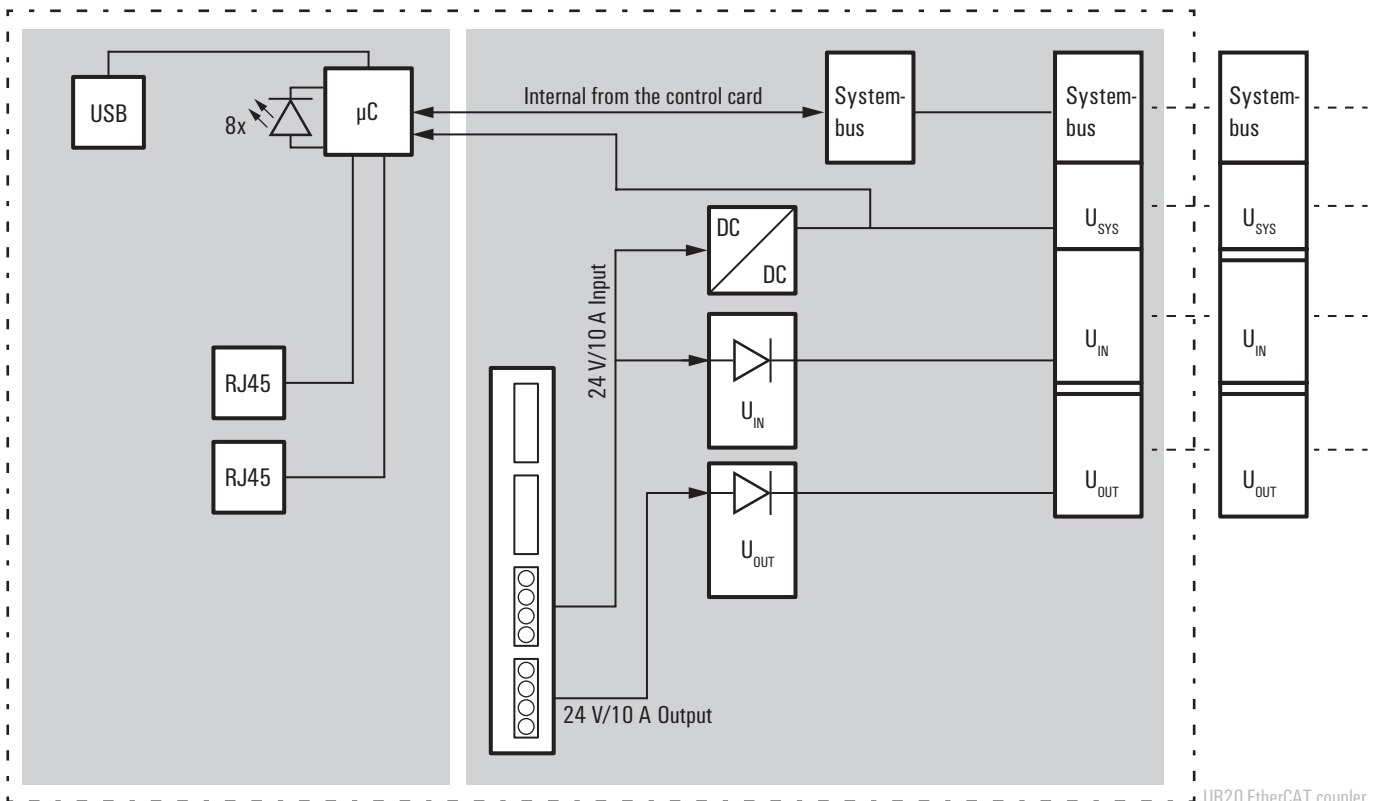

UR20 EtherCAT coupler

EtherCAT

- 2 x 10 A current paths
- Web server
- System supply of 64 I/O modules
- Temperature range -20... +60 °C
- Various EtherCAT services

UR20-FBC-EC



Technical data

System data	
Connection	2 x RJ-45
Field bus protocol	EtherCAT
Process data	8 kBytes
Parameter data	1.024 Bytes
Diagnostic data	1.024 Bytes
Max. number of modules	64
Configuration interface	USB 2.0
Transmission rate of field bus	100 Mbit/s
Transmission speed of u-remote system bus	48 Mbit/s
Supply	
Supply voltage for system and inputs	24 V DC +20 % / - 15 %
Supply voltage for outputs	24 V DC +20 % / - 15 %
Feed current for input modules, max.	10 A
Feed current for output modules, max.	10 A
Current consumption (I _N in power segment of field bus coupler), typ.	130 mA
General data	
Weight	220 g
Dimensions (H/W/D)	120 mm (with catch lever 128 mm) x 52 mm x 76 mm
Note	
Download of ESI-file on www.weidmueller.com	

Ordering data

Module variants	
Field bus coupler, EtherCAT	
Note	
A termination kit (UR20-EBK-ACC) is included in the coupler package	

Type	Qty.	Order No.
UR20-FBC-EC	1	1334910000

Accessories

Coding elements	
Termination kit	
Swivel marker	
Connection marker for pusher custom printing	
Connection marker for pusher neutral	
Module marker for custom printing	
Module marker for neutral	
Thermotransfer version (Material: Polyester)	
Thermotransfer version (Material: Polyester)	
Paper version for Laserprinter	
Replacement parts	
Plug-in connector unit	
Note	

Type	Qty.	Order No.
KOSM BHZ5.00	100	1483050000
UR20-EBK-ACC	5	1346610000
UR20-SM-ACC	20	1339920000
PM 2.7/2.6 MC SDR	192	1323700000
PM 2.7/2.6 MC NE WS	960	1323710000
DEK 5/8-11.5 MC SDR	100	1341610000
DEK 5/8-11.5 MC NE WS	500	1341630000
THM UR20 GE * ¹⁾	1	1429910000
THM UR20 WS * ¹⁾	1	1429420000
ESD UR20 DIN A4 WS * ²⁾	10	1429430000
UR20-PK-1334910000-SP	5	1484440000

*¹⁾ 1 roll = 1000 label = 1 Qty.
*²⁾ 1 sheet = 60 label = 1 Qty.

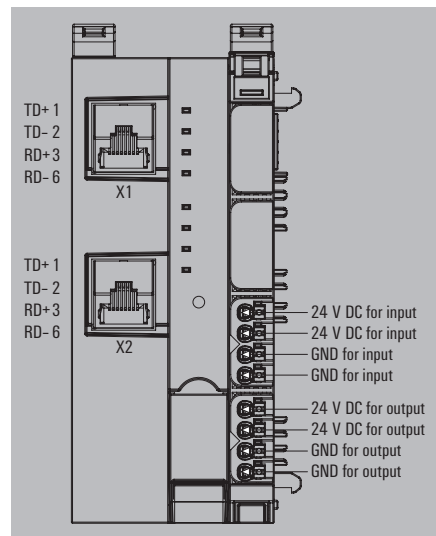

Product standard	IEC 61131-2
EMC	EN 61000
ATEX	EN 60079
UL	UL 508



Let's connect.

Modbus-TCP field bus coupler

Web server tool; two RJ45 ports; 10/100 Mbit/s

IP 20
A

System safety around the globe is provided by the Modbus-TCP version, which is stated in IEC 61158 as an Industrial Ethernet Standard. The UR20-FBC-MOD-TCP from Weidmüller is a field bus coupler designed in accordance with IEC 61158. With options for connecting up to 64 u-remote participants, it serves as the head module for the u-remote system bus.

The coupler can be activated with a system-independent web server application via the USB service interface or the Ethernet ports. All information, such as diagnoses, status values and parameters, can therefore be read out. All connected inputs can also be simulated or outputs set. The system's initial power supply is already integrated in the field bus coupler. Power is supplied via two 4-pin connectors, separated into the input and output current paths.

Since the Modbus-TCP products from Weidmüller make full use of all the latest technological possibilities, such as diagnosis options, they actively support your application in the most important tasks – from engineering and commissioning to fault diagnosis.

More Performance. Simplified.

Block diagram UR20-FBC-MOD-TCP

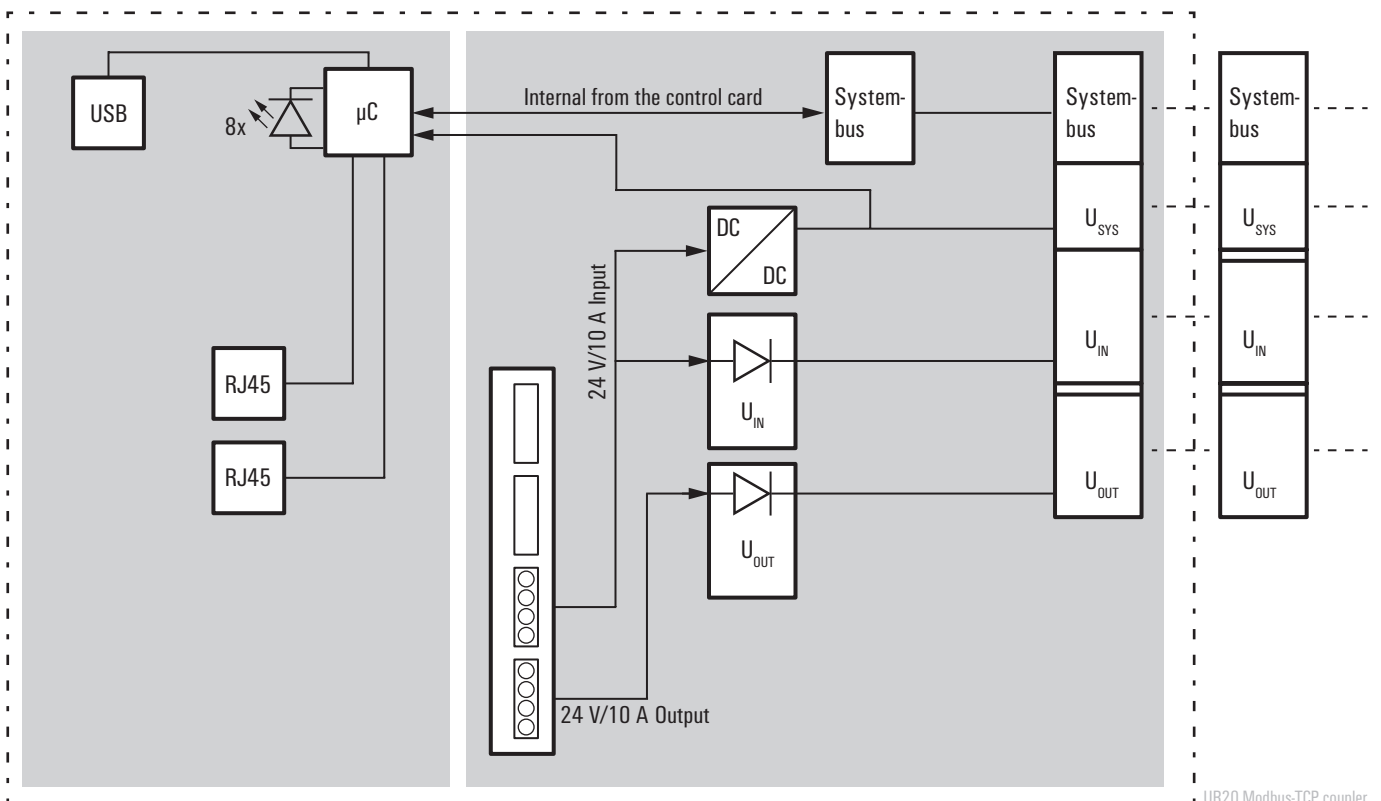

UR20 Modbus-TCP coupler

Modbus-TCP

- 2 x 10 A current paths
- Various Modbus services
- Web server
- System supply of 64 I/O modules
- Temperature range -20... +60 °C

UR20-FBC-MOD-TCP



Technical data

System data	
Connection	2 x RJ-45
Field bus protocol	Modbus TCP
Process data	8 kBytes
Parameter data	1.024 Bytes
Diagnostic data	1.024 Bytes
Max. number of modules	64
Configuration interface	USB 2.0
Transmission rate of field bus	100 Mbit/s
Transmission speed of u-remote system bus	48 Mbit/s
Supply	
Supply voltage for system and inputs	24 V DC +20 % / -15 %
Supply voltage for outputs	24 V DC +20 % / -15 %
Feed current for input modules, max.	10 A
Feed current for output modules, max.	10 A
Current consumption (I _N in power segment of field bus coupler), typ.	112 mA
General data	
Weight	220 g
Dimensions (H/W/D)	120 mm (with catch lever 128 mm) x 52 mm x 76 mm

2 x RJ-45
Modbus TCP
8 kBytes
1.024 Bytes
1.024 Bytes
64
USB 2.0
100 Mbit/s
48 Mbit/s
24 V DC +20 % / -15 %
24 V DC +20 % / -15 %
10 A
10 A
112 mA
220 g
120 mm (with catch lever 128 mm) x 52 mm x 76 mm

Ordering data

Module variants	
Field bus coupler, Modbus TCP	
Note	

Type	Qty.	Order No.
UR20-FBC-MOD-TCP	1	1334930000
A termination kit (UR20-EBK-ACC) is included in the coupler package		

Accessories

Coding elements		
Termination kit		
Swivel marker		
Connection marker for pusher custom printing		
Connection marker for pusher neutral		
Module marker for custom printing		
Module marker for neutral		
Thermotransfer version (Material: Polyester)		
Thermotransfer version (Material: Polyester)		
Paper version for Laserprinter		
Replacement parts		
Plug-in connector unit		
Note		

Type	Qty.	Order No.
KOSM BHZ5.00	100	1483050000
UR20-EBK-ACC	5	1346610000
UR20-SM-ACC	20	1339920000
PM 2.7/2.6 MC SDR	192	1323700000
PM 2.7/2.6 MC NE WS	960	1323710000
DEK 5/8-11.5 MC SDR	100	1341610000
DEK 5/8-11.5 MC NE WS	500	1341630000
THM UR20 GE * ¹⁾	1	1429910000
THM UR20 WS * ¹⁾	1	1429420000
ESD UR20 DIN A4 WS * ²⁾	10	1429430000
UR20-PK-1334930000-SP	5	1484130000
* ¹⁾ 1 roll = 1000 label = 1 Qty.		
* ²⁾ 1 sheet = 60 label = 1 Qty.		

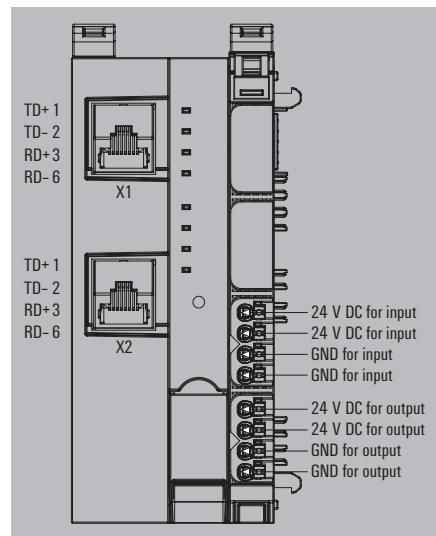

Product standard	IEC 61131-2
EMC	EN 61000
ATEX	EN 60079
UL	UL 508



Let's connect.

Digital input modules

Positive switching; Reverse polarity protection

IP 20
A

Digital input modules from Weidmüller are available in different versions and are used primarily to receive binary control signals from sensors, transmitters, switches or proximity switches. Thanks to their flexible design, they will satisfy your need for well co-ordinated project planning with reserve potential.

All modules are available with 4, 8 or 16 inputs and comply fully with IEC 61131-2. The digital inputs are for Type 1 and Type 3 sensors in accordance with the standard. With a maximum input frequency of up to 1 kHz, they are used in many different applications. The variant for PLC interface units enables rapid cabling to the proven Weidmüller interface sub-assemblies using system cables. This ensures rapid incorporation into your overall system. Two modules with a timestamp function are able to capture binary signals and to provide a timestamp in 1 μ s resolution.

The module electronics supply the connected sensors from the input current path (U_{IN}).

UR20-4DI-P block diagram example

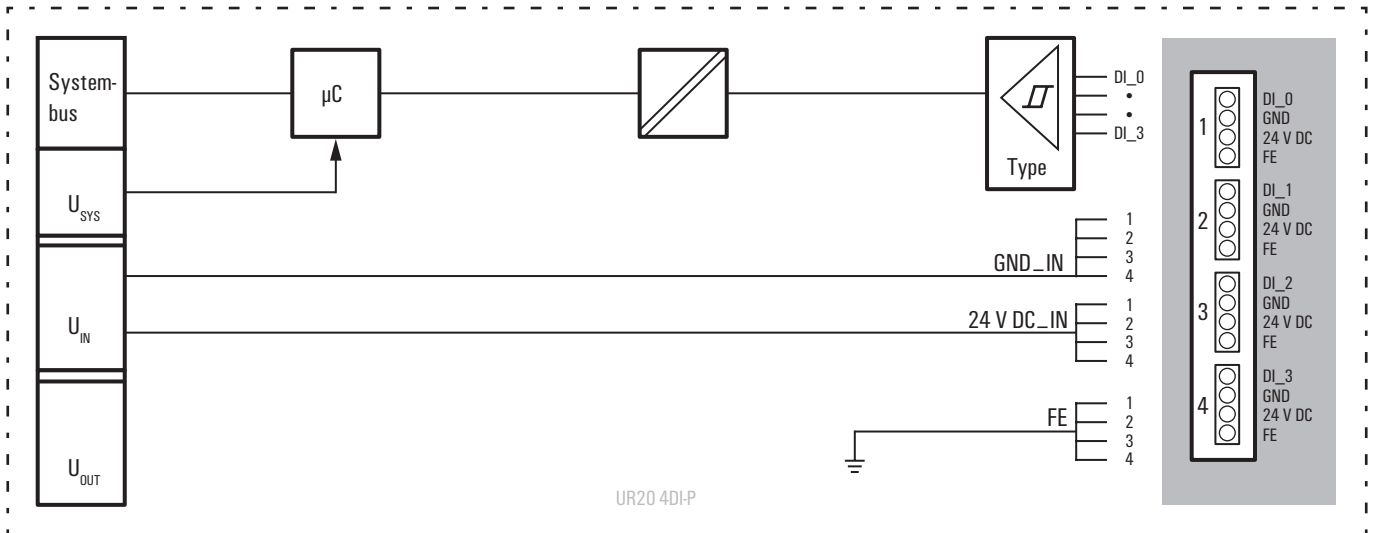

4DI-P

- 4 digital inputs for sensors such as transmitters, switches and proximity sensors
- Positive switching
- Reverse polarity protection
- 2-wire, 3-wire, 3-wire+FE connection
- Input filter can be set channel by channel
- Integrated sensor supply
- Types 1 and 3 acc. to IEC 61131-2

UR20-4DI-P



Technical data

System data	
Interface	u-remote system bus
Transmission rate of system bus	48 Mbit/s
Galvanic isolation	yes, DC 500 V between current paths
Supply	
Voltage supply	24 V DC +20 % / - 15 % via the system bus
Current consumption (I _N in power segment of field bus coupler), typ.	8 mA
Current consumption (I _N in the respective power segment)	< 12 mA + sensor feed
Digital inputs	
Number	4
Input Type	Types 1 and 3, IEC 61131-2
Input filter	adjustable, up to 40 ms
Input voltage, low	< 5 V
Input voltage, high	> 11 V
Sensor supply	yes
Sensor connection	2-wire, 3-wire, 3-wire+FE
Reverse polarity protection	yes
Module diagnosis	yes
Individual channel diagnosis	no
General data	
Weight	87 g
Dimensions (H/W/D)	120 mm (with catch lever 128 mm) x 11,5 mm x 76 mm

Ordering data

Module variants	
Digital input module, 4 channels	

Type	Qty.	Order No.
UR20-4DI-P	1	1315170000

Accessories

Accessories	
Coding elements	KOSM BHZ5.00 100 1483050000
Termination kit	UR20-EBK-ACC 5 1346610000
Swivel marker	UR20-SM-ACC 20 1339920000
Connection marker for pusher custom printing	PM 2.7/2.6 MC SDR 192 1323700000
Connection marker for pusher neutral	PM 2.7/2.6 MC NE WS 960 1323710000
Module marker for custom printing	DEK 5/8-11.5 MC SDR 100 1341610000
Module marker for neutral	DEK 5/8-11.5 MC NE WS 500 1341630000
Thermotransfer version (Material: Polyester)	THM UR20 GE * ¹⁾ 1 1429910000
Thermotransfer version (Material: Polyester)	THM UR20 WS * ¹⁾ 1 1429420000
Paper version for Laserprinter	ESO UR20 DIN A4 WS * ²⁾ 10 1429430000
Replacement parts	
Electronics module	UR20-EM-1315170000-SP 1 1346640000
Basic module	UR20-BM-SP 5 1350930000
Plug-in connector unit	UR20-PK-1315170000-SP 5 1346440000
Note	

Type	Qty.	Order No.
KOSM BHZ5.00	100	1483050000
UR20-EBK-ACC	5	1346610000
UR20-SM-ACC	20	1339920000
PM 2.7/2.6 MC SDR	192	1323700000
PM 2.7/2.6 MC NE WS	960	1323710000
DEK 5/8-11.5 MC SDR	100	1341610000
DEK 5/8-11.5 MC NE WS	500	1341630000
THM UR20 GE * ¹⁾	1	1429910000
THM UR20 WS * ¹⁾	1	1429420000
ESO UR20 DIN A4 WS * ²⁾	10	1429430000
UR20-EM-1315170000-SP	1	1346640000
UR20-BM-SP	5	1350930000
UR20-PK-1315170000-SP	5	1346440000

*¹⁾ 1 roll = 1000 label = 1 Qty.
 *²⁾ 1 sheet = 60 label = 1 Qty.

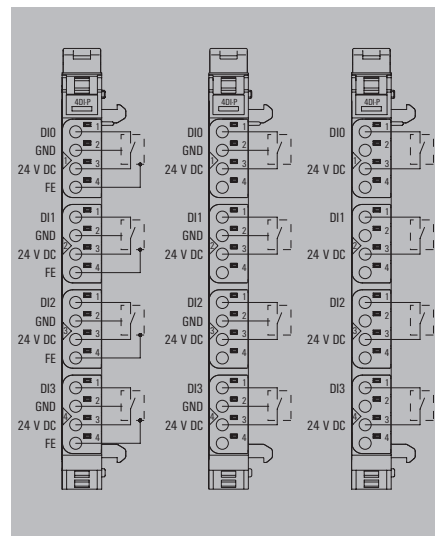

Product standard	IEC 61131-2
EMC	EN 61000
ATEX	EN 60079
UL	UL 508



Let's connect.

8DI-P-2W

- 8 digital inputs for sensors such as transmitters, switches and proximity sensors
- Positive switching
- Reverse polarity protection
- 2-wire connection
- Input filter can be set channel by channel
- Types 1 and 3 acc. to IEC 61131-2

UR20-8DI-P-2W



Technical data

System data	
Interface	u-remote system bus
Transmission rate of system bus	48 Mbit/s
Galvanic isolation	yes, DC 500 V between current paths
Supply	
Voltage supply	24 V DC +20 % / - 15 % via the system bus
Current consumption (I _N in power segment of field bus coupler), typ.	8 mA
Current consumption (I _N in the respective power segment)	< 22 mA
Digital inputs	
Number	8
Input Type	Types 1 and 3, IEC 61131-2
Input filter	adjustable, up to 40 ms
Input voltage, low	< 5 V
Input voltage, high	> 11 V
Sensor supply	no
Sensor connection	2-wire
Reverse polarity protection	yes
Module diagnosis	yes
Individual channel diagnosis	no
General data	
Weight	83 g
Dimensions (H/W/D)	120 mm (with catch lever) 128 mm x 11,5 mm x 76 mm

Ordering data

Module variants	
Digital input module, 8 channels, 2-wire	

Type	Qty.	Order No.
UR20-8DI-P-2W	1	1315180000

Accessories

Accessories	
Coding elements	
Termination kit	
Swivel marker	
Connection marker for pusher custom printing	
Connection marker for pusher neutral	
Module marker for custom printing	
Module marker for neutral	
Thermotransfer version (Material: Polyester)	
Thermotransfer version (Material: Polyester)	
Paper version for Laserprinter	
Replacement parts	
Electronics module	
Basic module	
Plug-in connector unit	
Note	

Type	Qty.	Order No.
KOSM BHZ5.00	100	1483050000
UR20-EBK-ACC	5	1346610000
UR20-SM-ACC	20	1339920000
PM 2.7/2.6 MC SDR	192	1323700000
PM 2.7/2.6 MC NE WS	960	1323710000
DEK 5/8-11.5 MC SDR	100	1341610000
DEK 5/8-11.5 MC NE WS	500	1341630000
THM UR20 GE * ¹⁾	1	1429910000
THM UR20 WS * ¹⁾	1	1429420000
ESO UR20 DIN A4 WS * ²⁾	10	1429430000
UR20-EM-1315080000-SP	1	1346650000
UR20-BM-SP	5	1350930000
UR20-PK-1315180000-SP	5	1346430000

*¹⁾ 1 roll = 1000 label = 1 Qty.
*²⁾ 1 sheet = 60 label = 1 Qty.

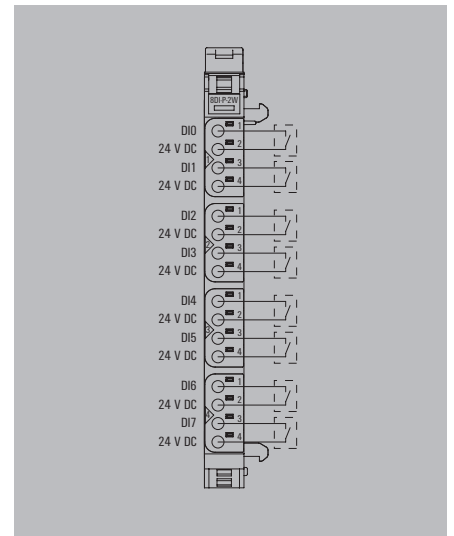

Product standard	IEC 61131-2
EMC	EN 61000
ATEX	EN 60079
UL (in preparation)	UL 508



Let's connect.

8DI-P-3W

- 8 digital inputs for sensors such as transmitters, switches and proximity sensors
- Positive switching
- Reverse polarity protection
- 2-wire and 3-wire connection
- Input filter can be set channel by channel
- Integrated sensor supply
- Types 1 and 3 acc. to IEC 61131-2

UR20-8DI-P-3W



Technical data

System data	
Interface	u-remote system bus
Transmission rate of system bus	48 Mbit/s
Galvanic isolation	yes, DC 500 V between current paths
Supply	
Voltage supply	24 V DC +20 % / - 15 % via the system bus
Current consumption (I _N in power segment of field bus coupler), typ.	8 mA
Current consumption (I _N in the respective power segment)	< 22 mA + sensor feed
Digital inputs	
Number	8
Input Type	Types 1 and 3, IEC 61131-2
Input filter	adjustable, up to 40 ms
Input voltage, low	< 5 V
Input voltage, high	> 11 V
Sensor supply	yes
Sensor connection	2-wire, 3-wire
Reverse polarity protection	yes
Module diagnosis	yes
Individual channel diagnosis	no
General data	
Weight	83 g
Dimensions (H/W/D)	120 mm (with catch lever) 128 mm x 11,5 mm x 76 mm

Ordering data

Module variants	
Digital input module, 8 channels, 3-wire	

Type	Qty.	Order No.
UR20-8DI-P-3W	1	1394400000

Accessories

Accessories	
Coding elements	KOSM BHZ5.00 100 1483050000
Termination kit	UR20-EBK-ACC 5 1346610000
Swivel marker	UR20-SM-ACC 20 1339920000
Connection marker for pusher custom printing	PM 2.7/2.6 MC SDR 192 1323700000
Connection marker for pusher neutral	PM 2.7/2.6 MC NE WS 960 1323710000
Module marker for custom printing	DEK 5/8-11.5 MC SDR 100 1341610000
Module marker for neutral	DEK 5/8-11.5 MC NE WS 500 1341630000
Thermotransfer version (Material: Polyester)	THM UR20 GE * ¹⁾ 1 1429910000
Thermotransfer version (Material: Polyester)	THM UR20 WS * ¹⁾ 1 1429420000
Paper version for Laserprinter	ESO UR20 DIN A4 WS * ²⁾ 10 1429430000
Replacement parts	
Electronics module	UR20-EM-1394400000-SP 1 1434220000
Basic module	UR20-BM-SP 5 1350930000
Plug-in connector unit	UR20-PK-1394400000-SP 5 1411430000
Note	

Type	Qty.	Order No.
UR20-EM-1394400000-SP	1	1434220000
UR20-BM-SP	5	1350930000
UR20-PK-1394400000-SP	5	1411430000

*¹⁾ 1 roll = 1000 label = 1 Qty.
*²⁾ 1 sheet = 60 label = 1 Qty.

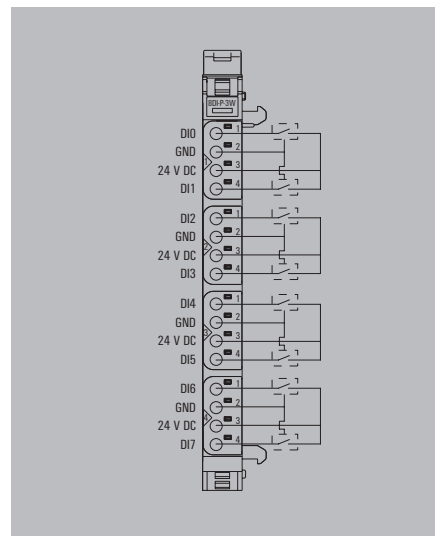

Product standard	IEC 61131-2
EMC	EN 61000
ATEX	EN 60079
UL	UL 508



Let's connect.

8DI-P-3W-HD

- 8 plugs with 4 connections per module
- 8 digital inputs for sensors such as transmitters, switches and proximity sensors
- Positive switching
- Reverse polarity protection
- 2-wire and 3-wire connection
- Input filter can be set channel by channel
- Integrated sensor supply
- Types 1 and 3 acc. to IEC 61131-2

UR20-8DI-P-3W-HD

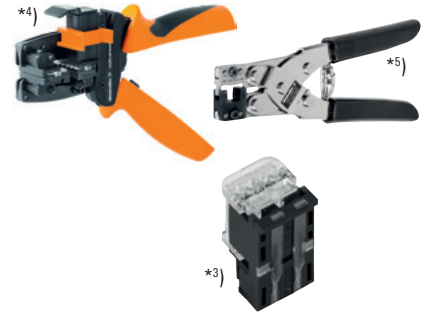

Technical data

System data	
Interface	u-remote system bus
Transmission rate of system bus	48 Mbit/s
Galvanic isolation	yes, DC 500 V between current paths
Supply	
Voltage supply	24 V DC +20 % / -15 % via the system bus
Current consumption (I _N in power segment of field bus coupler), typ.	8 mA
Current consumption (I _N in the respective power segment)	< 30 mA + sensor feed
Digital inputs	
Number	8
Input Type	Types 1 and 3, IEC 61131-2
Input filter	adjustable, up to 40 ms
Input voltage, low	< 5 V
Input voltage, high	> 11 V
Sensor supply	maximum 150 mA per channel
Sensor connection	2-wire, 3-wire
Reverse polarity protection	yes
Module diagnosis	yes
Individual channel diagnosis	no
General data	
Weight	83 g
Dimensions (H/W/D)	120 mm (with catch lever 128 mm) x 11,5 mm x 76 mm

Ordering data

Module variants	
Digital input module, 8 channels, 3-wire, HD plug	

Type	Qty.	Order No.
UR20-8DI-P-3W-HD	1	1315190000

Accessories

Coding elements	
Termination kit	
Swivel marker	
*3) HD-Plug	
*4) Stripping tool	
*5) Pressing tool	
Module marker for custom printing	
Module marker for neutral	
Thermotransfer version (Material: Polyester)	
Thermotransfer version (Material: Polyester)	
Paper version for Laserprinter	
Replacement parts	
Electronics module	
Basic module	
Plug-in connector unit	
Note	

Type	Qty.	Order No.
KOSM BHZ5.00	100	1483050000
UR20-EBK-ACC	5	1346610000
UR20-SM-ACC	20	1339920000
UR20-PGO.35	8	1469340000
multi-stripax 6-16	1	9202210000
PWZ-UR20-HD	1	1525820000
DEK 5/8-11.5 MC SDR	100	1341610000
DEK 5/8-11.5 MC NE WS	500	1341630000
THM UR20 GE *1)	1	1429910000
THM UR20 WS *1)	1	1429420000
ESD UR20 DIN A4 WS *2)	10	1429430000
UR20-EM-1315190000-SP	1	1346670000
UR20-BM-1315190000-SP	5	1350930000
UR20-PK-1315190000-SP	5	1518800000

*1) 1 roll = 1000 label = 1 Qty.
*2) 1 sheet = 60 label = 1 Qty.

Note: Please order connector separately

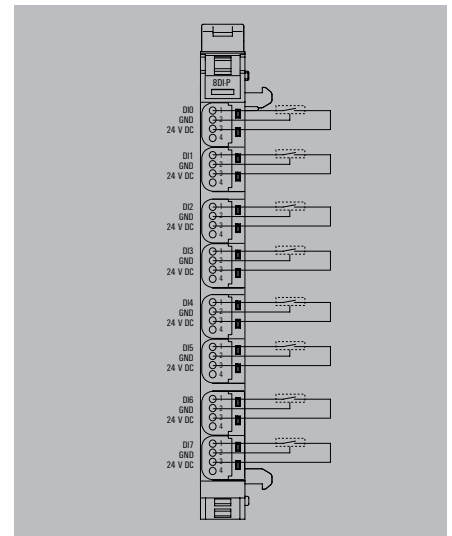

Product standard	IEC 61131-2
EMC	EN 61000
ATEX	EN 60079
UL (in preparation)	UL 508



Let's connect.

16DI-P

- 16 digital inputs
- Positive switching
- Reverse polarity protection
- 1-wire connection
- Permanently set input filter, 3 ms
- Types 1 and 3 acc. to IEC 61131-2

UR20-16DI-P



Technical data

System data	
Interface	u-remote system bus
Transmission rate of system bus	48 Mbit/s
Galvanic isolation	yes, DC 500 V between current paths
Supply	
Voltage supply	24 V DC +20 % / - 15 % via the system bus
Current consumption (I _N in power segment of field bus coupler), typ.	8 mA
Current consumption (I _N in the respective power segment)	< 42 mA
Digital inputs	
Number	16
Input Type	Types 1 and 3, IEC 61131-2
Input filter	3 ms
Input voltage, low	< 5 V
Input voltage, high	> 11 V
Sensor supply	no
Sensor connection	1-wire
Reverse polarity protection	yes
Module diagnosis	yes
Individual channel diagnosis	no
General data	
Weight	87 g
Dimensions (H/W/D)	120 mm (with catch lever) x 11,5 mm x 76 mm

Ordering data

Module variants	
Digital input module, 16 channels	

Type	Qty.	Order No.
UR20-16DI-P	1	1315200000

Accessories

Accessories	
Coding elements	
Termination kit	
Swivel marker	
Connection marker for pusher custom printing	
Connection marker for pusher neutral	
Module marker for custom printing	
Module marker for neutral	
Thermotransfer version (Material: Polyester)	
Thermotransfer version (Material: Polyester)	
Paper version for Laserprinter	
Replacement parts	
Electronics module	
Basic module	
Plug-in connector unit	
Note	

Type	Qty.	Order No.
KOSM BHZ5.00	100	1483050000
UR20-EBK-ACC	5	1346610000
UR20-SM-ACC	20	1339920000
PM 2.7/2.6 MC SDR	192	1323700000
PM 2.7/2.6 MC NE WS	960	1323710000
DEK 5/8-11.5 MC SDR	100	1341610000
DEK 5/8-11.5 MC NE WS	500	1341630000
THM UR20 GE * ¹⁾	1	1429910000
THM UR20 WS * ¹⁾	1	1429420000
ESO UR20 DIN A4 WS * ²⁾	10	1429430000
UR20-EM-1315200000-SP	1	1346680000
UR20-BM-SP	5	1350930000
UR20-PK-1315200000-SP	5	1346400000

*¹⁾ 1 roll = 1000 label = 1 Qty.
*²⁾ 1 sheet = 60 label = 1 Qty.

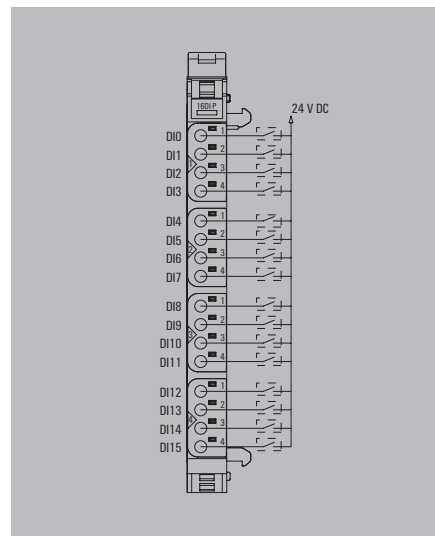

Product standard	IEC 61131-2
EMC	EN 61000
ATEX	EN 60079
UL	UL 508



Let's connect.

16DI-P-PLC-INT

- 16 digital inputs
- Positive switching
- Reverse polarity protection
- For connecting a PLC interface element
- Permanently set input filter, 3 ms
- Types 1 and 3 acc. to IEC 61131-2

UR20-16DI-P-PLC-INT



Technical data

System data	
Interface	u-remote system bus
Transmission rate of system bus	48 Mbit/s
Galvanic isolation	yes, DC 500 V between current paths
Supply	
Voltage supply	24 V DC +20 % / - 15 % via the system bus
Current consumption (I _N in power segment of field bus coupler), typ.	8 mA
Current consumption (I _N external)	< 42 mA
Digital inputs	
Number	16
Input Type	Types 1 and 3, IEC 61131-2
Input filter	3 ms
Input voltage, low	< 5 V
Input voltage, high	> 11 V
Sensor supply	external
Sensor connection	PLC interface
Reverse polarity protection	yes
Module diagnosis	yes
Individual channel diagnosis	no
General data	
Weight	73 g
Dimensions (H/W/D)	120 mm (with catch lever) 128 mm x 11,5 mm x 76 mm

System data		
Interface	u-remote system bus	
Transmission rate of system bus	48 Mbit/s	
Galvanic isolation	yes, DC 500 V between current paths	
Supply		
Voltage supply	24 V DC +20 % / - 15 % via the system bus	
Current consumption (I _N in power segment of field bus coupler), typ.	8 mA	
Current consumption (I _N external)	< 42 mA	
Digital inputs		
Number	16	
Input Type	Types 1 and 3, IEC 61131-2	
Input filter	3 ms	
Input voltage, low	< 5 V	
Input voltage, high	> 11 V	
Sensor supply	external	
Sensor connection	PLC interface	
Reverse polarity protection	yes	
Module diagnosis	yes	
Individual channel diagnosis	no	
General data		
Weight	73 g	
Dimensions (H/W/D)	120 mm (with catch lever) 128 mm x 11,5 mm x 76 mm	

Ordering data

Module variants	
Digital input module, 16 channels, PLC interface	

Type	Qty.	Order No.
UR20-16DI-P-PLC-INT	1	1315210000

Accessories

Accessories	
Coding elements	
Termination kit	
Swivel marker	
Connection marker for pusher custom printing	
Connection marker for pusher neutral	
Module marker for custom printing	
Module marker for neutral	
Thermotransfer version (Material: Polyester)	
Thermotransfer version (Material: Polyester)	
Paper version for Laserprinter	
Replacement parts	
Electronics module	
Basic module	
Plug-in connector unit	
PLC interface element	
Pre-assembled cable, 1m	
Note	

Type	Qty.	Order No.
KOSM BHZ5.00	100	1483050000
UR20-EBK-ACC	5	1346610000
UR20-SM-ACC	20	1339920000
PM 2.7/2.6 MC SDR	192	1323700000
PM 2.7/2.6 MC NE WS	960	1323710000
DEK 5/8-11.5 MC SDR	100	1341610000
DEK 5/8-11.5 MC NE WS	500	1341630000
THM UR20 GE * ¹⁾	1	1429910000
THM UR20 WS * ¹⁾	1	1429420000
ESO UR20 DIN A4 WS * ²⁾	10	1429430000
Replacement parts		
UR20-EM-1315210000-SP	1	1346690000
UR20-BM-SP	5	1350930000
UR20-PK-1315210000-SP	5	1346590000
RS 16IO 1W H S	1	9445700000
PAC-UNIV-HE20-LCH-1M	1	7789306010

*¹⁾ 1 roll = 1000 label = 1 Qty.
 *²⁾ 1 sheet = 60 label = 1 Qty.

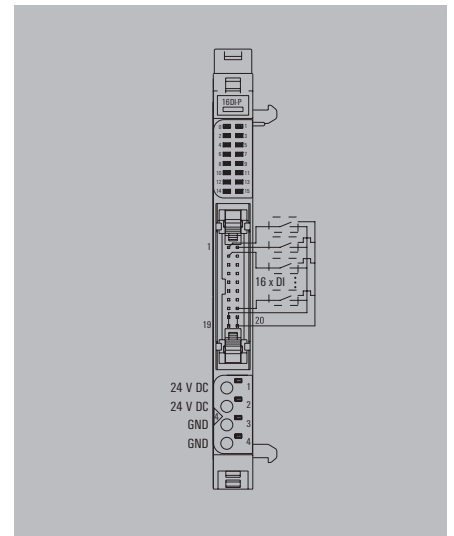

Product standard	
Product standard	IEC 61131-2
EMC	EN 61000
ATEX	EN 60079
UL	UL 508



Let's connect.

2DI-P-TS

- 2 digital inputs for sensors such as transmitters, switches and proximity sensors
- Positive switching
- 2-wire, 3-wire, 3-wire+FE connection
- Input filter can be set channel by channel
- Types 1 and 3 acc. to IEC 61131-2
- 1 µs Timestamp resolution

UR20-2DI-P-TS



Technical data

System data	
Interface	u-remote system bus
Transmission rate of system bus	48 Mbit/s
Galvanic isolation	yes, DC 500 V between current paths
Supply	
Voltage supply	24 V DC +20 % / - 15 % via the system bus
Current consumption (I _N in power segment of field bus coupler), typ.	8 mA
Current consumption (I _N in the respective power segment)	< 10 mA + sensor feed
Digital Inputs	
Number	2
Input Type	Type 1 und 3, IEC 61131-2
Input filter	adjustable, up to 40 ms
Input voltage, low	< 5 V
Input voltage, high	> 11 V
Sensor supply	yes
Sensor connection	2-wire, 3-wire, 3-wire+FE
Reverse polarity protection	yes
Module diagnosis	yes
Individual channel diagnosis	no
Data width Timestamp	16 Bit
Resolution Timestamp	1 µs
General data	
Weight	83 g
Dimensions (H/W/D)	120 mm (with catch lever 128 mm) x 11.5 mm x 76 mm

Type	Qty.	Order No.
UR20-2DI-P-TS	1	1460140000

Ordering data

Module variants	
Digital input module, 2 channels, Timestamp	

Accessories

Accessories			
Coding elements	KDSM BHZ5.00	100	1483050000
Termination kit	UR20-EBK-ACC	5	1346610000
Swivel marker	UR20-SM-ACC	20	1339920000
Connection marker for pusher custom printing	PM 2.7/2.6 MC SDR	192	1323700000
Connection marker for pusher neutral	PM 2.7/2.6 MC NE WS	960	1323710000
Module marker for custom printing	DEK 5/8-11.5 MC SDR	100	1341610000
Module marker for neutral	DEK 5/8-11.5 MC NE WS	500	1341630000
Thermotransfer version (Material: Polyester)	THM UR20 GE * ¹⁾	1	1429910000
Thermotransfer version (Material: Polyester)	THM UR20 WS * ¹⁾	1	1429420000
Paper version for Laserprinter	ESO UR20 DIN A4 WS * ²⁾	10	1429430000
Replacement parts			
Electronics module	UR20-EM-1460140000-SP	1	1463690000
Basic module	UR20-BM-SP	5	1350930000
Plug-in connector unit	UR20-PK-1460140000-SP	5	1484110000
Note			
* ¹⁾ 1 roll = 1000 label = 1 Qty.			
* ²⁾ 1 sheet = 60 label = 1 Qty.			

Product standard	IEC 61131-2
EMC	EN 61000
ATEX	EN 60079
UL (in preparation)	UL 508

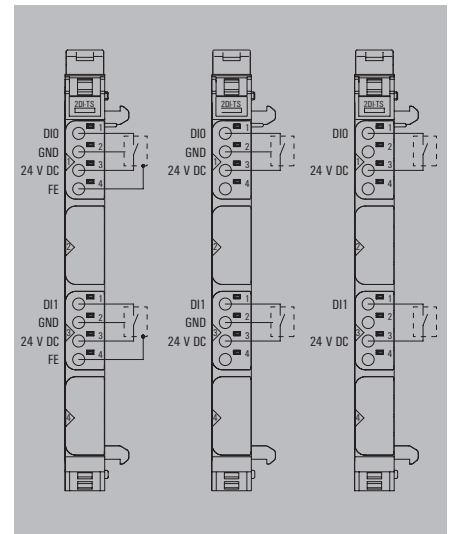

Let's connect.

4DI-P-TS

- 4 digital inputs for sensors such as transmitters, switches and proximity sensors
- Positive switching
- 2-wire, 3-wire, 3-wire+FE connection
- Input filter can be set channel by channel
- Types 1 and 3 acc. to IEC 61131-2
- 1 µs Timestamp resolution

UR20-4DI-P-TS



Technical data

System data	
Interface	u-remote system bus
Transmission rate of system bus	48 Mbit/s
Galvanic isolation	yes, DC 500 V between current paths
Supply	
Voltage supply	24 V DC +20 % / - 15 % via the system bus
Current consumption (I _N in power segment of field bus coupler), typ.	8 mA
Current consumption (I _N in the respective power segment)	< 10 mA + sensor feed
Digital Inputs	
Number	4
Input Type	Types 1 and 3, IEC 61131-2
Input filter	adjustable, up to 40 ms
Input voltage, low	< 5 V
Input voltage, high	> 11 V
Sensor supply	yes
Sensor connection	2-wire, 3-wire, 3-wire+FE
Reverse polarity protection	yes
Module diagnosis	yes
Individual channel diagnosis	no
Data width Timestamp	16 Bit
Resolution Timestamp	1 µs
General data	
Weight	87 g
Dimensions (H/W/D)	120 mm (with catch lever 128 mm) x 11.5 mm x 76 mm

Type	Qty.	Order No.
UR20-4DI-P-TS	1	1460150000

Ordering data

Module variants	
Digital input module, 4 channels, Timestamp	

Accessories

Accessories	
Coding elements	KOSM BHZ5.00
Termination kit	UR20-EBK-ACC
Swivel marker	UR20-SM-ACC
Connection marker for pusher custom printing	PM 2.7/2.6 MC SDR
Connection marker for pusher neutral	PM 2.7/2.6 MC NE WS
Module marker for custom printing	DEK 5/8-11.5 MC SDR
Module marker for neutral	DEK 5/8-11.5 MC NE WS
Thermotransfer version (Material: Polyester)	THM UR20 GE * ¹⁾
Thermotransfer version (Material: Polyester)	THM UR20 WS * ¹⁾
Paper version for Laserprinter	ESO UR20 DIN A4 WS * ²⁾
Replacement parts	
Electronics module	UR20-EM-1460150000-SP
Basic module	UR20-BM-SP
Plug-in connector unit	UR20-PK-1460150000-SP
Note	

Type	Qty.	Order No.
UR20-EM-1460150000-SP	1	1463680000
UR20-BM-SP	5	1350930000
UR20-PK-1460150000-SP	5	1484430000

*¹⁾ 1 roll = 1000 label = 1 Qty.
*²⁾ 1 sheet = 60 label = 1 Qty.

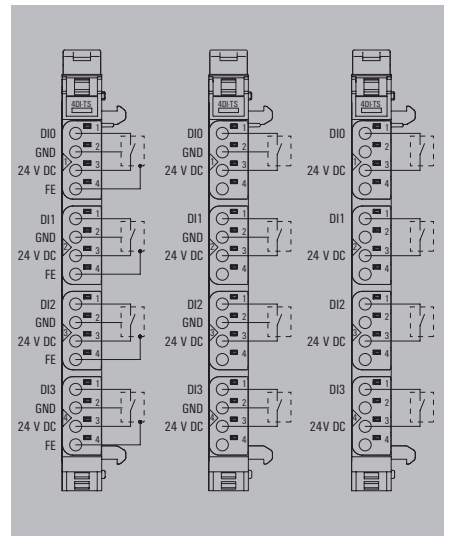

Product standard	IEC 61131-2
EMC	EN 61000
ATEX	EN 60079
UL (in preparation)	UL 508



Let's connect.

Digital output modules

Positive switching; short-circuit-proof; up to 3-wire+FE

IP 20
A

Digital output modules are available in the following variants: 4DO, 8DO with 2-wire technology, 16DO with or without PLC interface connection. They are used primarily for incorporating decentralised actuators.

All outputs are designed for DC-13 actuators acc. to DIN EN 60947-5-1 and IEC 61131-2 specifications. Just like the digital input modules, frequencies of up to 1 kHz are possible. Maximum system safety is ensured by protecting the outputs. This consists of an automatic restart following a short-circuit. Clearly recognisable LEDs also signal the status of the entire module as well as individual channels.

In addition to the standard applications of the digital output modules, the portfolio also includes special variants, such as the 4RO-SSR module for rapidly switching applications. Fitted with solid state technology, 0.5 A is available for each output. Furthermore, there is also the 4RO-CO relay module for power-intensive applications. This is equipped with four change-over contacts, optimised for a switching voltage of 277 V AC and designed for a switching current of 6 A. To serve negative switching requirements there is a parameterisable version of the 4DO Module.

The module electronics supply the connected actuators from the output current path (U_{OUT}).

UR20-4DO-P block diagram example

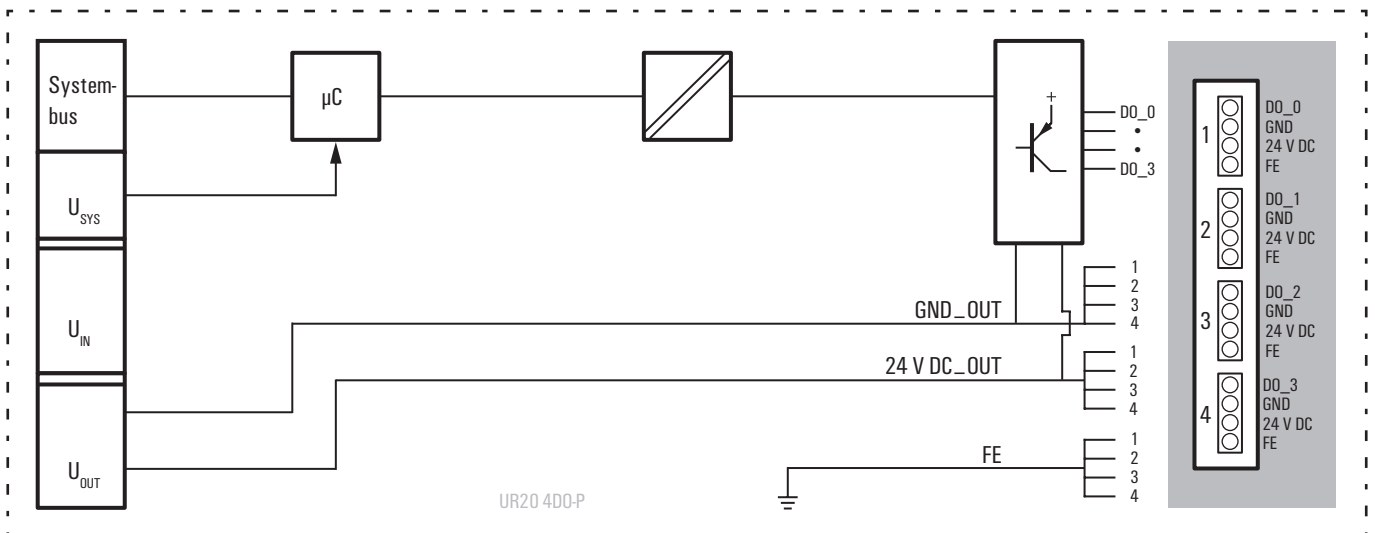

4DO-P

- 4 digital outputs
- Can be loaded up to 0.5 A per channel
- Short-circuit-proof
- 2-wire, 3-wire, 3-wire+FE connection
- Positive switching
- DC-13 load
- IEC 61131-2 compliant

UR20-4DO-P



Technical data

System data	
Interface	u-remote system bus
Transmission rate of system bus	48 Mbit/s
Galvanic isolation	yes, DC 500 V between current paths
Supply	
Voltage supply	24 V DC +20 % / - 15 % via the system bus
Current consumption (I _{IN} in power segment of field bus coupler), typ.	8 mA
Current consumption (I _{OUT} in the respective power segment)	10 mA + load
Digital outputs	
Number	4
Type of load	ohmic, inductive, lamp load
Response time, high	100 µs
Response time, low	250 µs
Output current per channel, max.	0.5 A
Output current per module, max.	2 A
Switching frequency max.	1 kHz
	*)
	1 kHz
Actuator connection	2-wire, 3-wire, 3-wire+FE
Short-circuit-proof	thermal
Non reactive	yes
Module diagnosis	yes
Individual channel diagnosis	no
Shut-down energy (inductive)	150 mJ / channel
Response time of protective circuit (current limitation)	< 100 µs (ambient temperature dependent)
General data	
Weight	86 g
Dimensions (H/W/D)	120 mm (with catch lever 128 mm) x 11,5 mm x 76 mm

Type	Qty.	Order No.
UR20-4DO-P	1	1315220000

*) For this and additional technical data, please refer to the manual available at www.weidmueller.de or scan the QR code below.

Ordering data

Module variants	
Digital output module, 4 channels	

Accessories

Coding elements	
Termination kit	
Swivel marker	
Connection marker for pusher custom printing	
Connection marker for pusher neutral	
Module marker for custom printing	
Module marker for neutral	
Thermotransfer version (Material: Polyester)	
Thermotransfer version (Material: Polyester)	
Paper version for Laserprinter	

Type	Qty.	Order No.
KOSM BHZ5 00	100	1483050000
UR20-EBK-ACC	5	1346610000
UR20-SM-ACC	20	1339920000
PM 2.7/2.6 MC SDR	192	1323700000
PM 2.7/2.6 MC NE WS	960	1323710000
DEK 5/8-11.5 MC SDR	100	1341610000
DEK 5/8-11.5 MC NE WS	500	1341630000
THM UR20 GE *)	1	1429910000
THM UR20 WS *)	1	1429420000
ESD UR20 DIN A4 WS *)	10	1429430000

Replacement parts	
Electronics module	UR20-EM-1315220000-SP
Basic module	UR20-BM-SP
Plug-in connector unit	UR20-PK-1315220000-SP

Note

UR20-EM-1315220000-SP	1	1346700000
UR20-BM-SP	5	1350930000
UR20-PK-1315220000-SP	5	1483960000

*) 1 roll = 1000 label = 1 Qty.
*) 1 sheet = 60 label = 1 Qty.

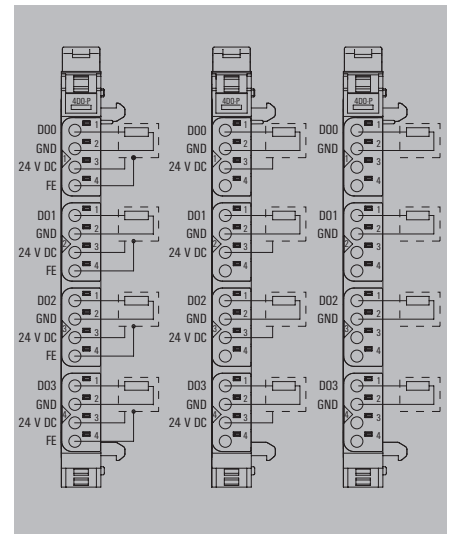

Product standard	IEC 61131-2
EMC	EN 61000
ATEX	EN 60079
UL	UL 508



Let's connect.

4D0-P-2A

- 4 digital outputs
- Module can be loaded up to 8 A
- Can be loaded up to 2 A per channel
- Short-circuit-proof
- 2-wire, 3-wire, 3-wire+FE connection
- Positive switching
- DC-13 load
- IEC 61131-2 compliant

UR20-4D0-P-2A



Technical data

System data	
Interface	u-remote system bus
Transmission rate of system bus	48 Mbit/s
Galvanic isolation	yes, DC 500 V between current paths
Supply	
Voltage supply	24 V DC +20 % / - 15 % via the system bus
Current consumption (I _{IN} in power segment of field bus coupler), typ.	8 mA
Current consumption (I _{OUT} in the respective power segment)	10 mA + load
Digital outputs	
Number	4
Type of load	ohmic, inductive, lamp load
Response time, high	100 µs
Response time, low	250 µs
Output current per channel, max.	2 A
Output current per module, max.	8 A
Switching frequency max.	1 kHz
	*)
	1 kHz
Actuator connection	2-wire, 3-wire, 3-wire+FE
Short-circuit-proof	thermal
Non reactive	yes
Module diagnosis	yes
Individual channel diagnosis	no
Shut-down energy (inductive)	150 mJ / channel
Response time of protective circuit (current limitation)	< 100 µs (ambient temperature dependent)
General data	
Weight	86 g
Dimensions (H/W/D)	120 mm (with catch lever 128 mm) x 11,5 mm x 76 mm

Ordering data

Module variants	
Digital output module, 4 channels, 2 A	

Type	Qty.	Order No.
UR20-4D0-P-2A	1	1315230000

*) For this and additional technical data, please refer to the manual available at www.weidmueller.de or scan the QR code below.

Accessories

Coding elements	
Termination kit	
Swivel marker	
Connection marker for pusher custom printing	
Connection marker for pusher neutral	
Module marker for custom printing	
Module marker for neutral	
Thermotransfer version (Material: Polyester)	
Thermotransfer version (Material: Polyester)	
Paper version for Laserprinter	

Type	Qty.	Order No.
KOSM BHZ5 00	100	1483050000
UR20-EBK-ACC	5	1346610000
UR20-SM-ACC	20	1339920000
PM 2.7/2.6 MC SDR	192	1323700000
PM 2.7/2.6 MC NE WS	960	1323710000
DEK 5/8-11.5 MC SDR	100	1341610000
DEK 5/8-11.5 MC NE WS	500	1341630000
THM UR20 GE *)	1	1429910000
THM UR20 WS *)	1	1429420000
ESO UR20 DIN A4 WS *)	10	1429430000

Replacement parts	
Electronics module	UR20-EM-1315230000-SP 1 1346710000
Basic module	UR20-BM-SP 5 1350930000
Plug-in connector unit	UR20-PK-1315230000-SP 5 1483970000
Note	

*) 1 roll = 1000 label = 1 Qty.
*) 1 sheet = 60 label = 1 Qty.

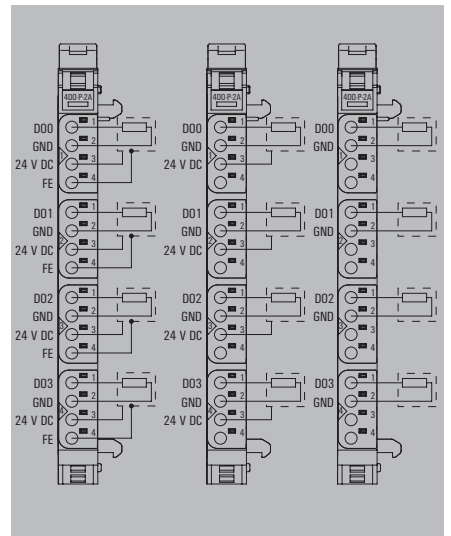

Product standard	IEC 61131-2
EMC	EN 61000
ATEX	EN 60079
UL	UL 508



Let's connect.

4DO-PN-2A

- 4 digital outputs
- Module can be loaded up to 8 A
- Can be loaded up to 2 A per channel
- Short-circuit-proof
- Positive or negative switching
- 2-wire, 3-wire, 3-wire+FE connection
- IEC 61131-2 compliant

UR20-4DO-PN-2A



Technical data

System data	
Interface	u-remote system bus
Transmission rate of system bus	48 Mbit/s
Galvanic isolation	yes, DC 500 V between current paths
Supply	
Voltage supply	24 V DC +20 % / - 15 % via the system bus
Current consumption (I _{IN} in power segment of field bus coupler), typ.	8 mA
Current consumption (I _{OUT} in the respective power segment)	10 mA + load
Digital outputs	
Number	4
Positive or negative switching	parameterise
Type of load	ohmic, inductive, lamp load
Response time, high	100 µs
Response time, low	250 µs
Output current per channel, max.	2 A
Output current per module, max.	8 A
Switching frequency max.	1 kHz
	*)
	1 kHz
Actuator connection	2-wire, 3-wire, 3-wire+FE
Short-circuit-proof	thermal
Non reactive	yes
Module diagnosis	yes
Individual channel diagnosis	no
Shut-down energy (inductive)	150 mJ / channel
Response time of protective circuit (current limitation)	< 100 µs (ambient temperature dependent)
General data	
Weight	87 g
Dimensions (H/W/D)	120 mm (with catch lever 128 mm) x 11.5 mm x 76 mm

Ordering data

Module variants	
Digital output module, 4 channels, positively or negatively switching	

Accessories

Coding elements	KDSM BHZ5.00	100	1483050000
Termination kit	UR20-EBK-ACC	5	1346610000
Swivel marker	UR20-SM-ACC	20	1339920000
Connection marker for pusher custom printing	PM 2.7/2.6 MC SDR	192	1323700000
Connection marker for pusher neutral	PM 2.7/2.6 MC NE WS	960	1323710000
Module marker for custom printing	DEK 5/8-11.5 MC SDR	100	1341610000
Module marker for neutral	DEK 5/8-11.5 MC NE WS	500	1341630000
Thermotransfer version (Material: Polyester)	THM UR20 GE * ¹⁾	1	1429910000
Thermotransfer version (Material: Polyester)	THM UR20 WS * ¹⁾	1	1429420000
Paper version for Laserprinter	ESO UR20 DIN A4 WS * ²⁾	10	1429430000
Ersatzteile			
Electronics module	UR20-EM-1394420000-SP	1	1480950000
Basic module	UR20-BM-SP	5	1350930000
Plug-in connector unit	UR20-PK-1394420000-SP	5	1483980000
Note			

Type	Qty.	Order No.
UR20-4DO-PN-2A	1	1394420000

*) For this and additional technical data, please refer to the manual available at www.weidmueller.de or scan the QR code below.

Type	Qty.	Order No.
KDSM BHZ5.00	100	1483050000
UR20-EBK-ACC	5	1346610000
UR20-SM-ACC	20	1339920000
PM 2.7/2.6 MC SDR	192	1323700000
PM 2.7/2.6 MC NE WS	960	1323710000
DEK 5/8-11.5 MC SDR	100	1341610000
DEK 5/8-11.5 MC NE WS	500	1341630000
THM UR20 GE * ¹⁾	1	1429910000
THM UR20 WS * ¹⁾	1	1429420000
ESO UR20 DIN A4 WS * ²⁾	10	1429430000
UR20-EM-1394420000-SP	1	1480950000
UR20-BM-SP	5	1350930000
UR20-PK-1394420000-SP	5	1483980000

*¹⁾ 1 roll = 1000 label = 1 Qty.
*²⁾ 1 sheet = 60 label = 1 Qty.

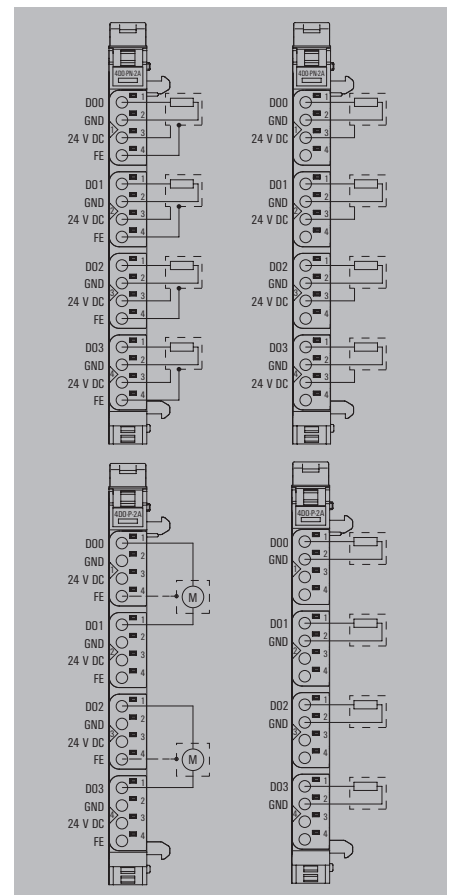

Product standard	IEC 61131-2
EMC	EN 61000
ATEX	EN 60079
UL (in preparation)	UL 508



Let's connect.

8DO-P

- 8 digital outputs
- Can be loaded up to 0.5 A per channel
- Short-circuit-proof
- 2-wire connection
- Positive switching
- DC-13 load
- IEC 61131-2 compliant

UR20-8DO-P



Technical data

System data	
Interface	u-remote system bus
Transmission rate of system bus	48 Mbit/s
Galvanic isolation	yes, DC 500 V between current paths
Supply	
Voltage supply	24 V DC +20 % / - 15 % via the system bus
Current consumption (I _{IN} in power segment of field bus coupler), typ.	8 mA
Current consumption (I _{OUT} in the respective power segment)	15 mA + load
Digital outputs	
Number	8
Type of load	ohmic, inductive, lamp load
Response time, high	100 µs
Response time, low	250 µs
Output current per channel, max.	0.5 A
Output current per module, max.	4 A
Switching frequency max.	1 kHz
	*)
	1 kHz
Actuator connection	2-wire
Short-circuit-proof	thermal
Non reactive	yes
Module diagnosis	yes
Individual channel diagnosis	no
Shut-down energy (inductive)	150 mJ / channel
Response time of protective circuit (current limitation)	< 100 µs (ambient temperature dependent)
General data	
Weight	87 g
Dimensions (H/W/D)	120 mm (with catch lever 128 mm) x 11,5 mm x 76 mm

Ordering data

Module variants	
Digital output module, 8 channels	

Type	Qty.	Order No.
UR20-8DO-P	1	1315240000

*) For this and additional technical data, please refer to the manual available at www.weidmueller.de or scan the QR code below.

Accessories

Coding elements	
Termination kit	
Swivel marker	
Connection marker for pusher custom printing	
Connection marker for pusher neutral	
Module marker for custom printing	
Module marker for neutral	
Thermotransfer version (Material: Polyester)	
Thermotransfer version (Material: Polyester)	
Paper version for Laserprinter	

Type	Qty.	Order No.
KOSM BHZ5 00	100	1483050000
UR20-EBK-ACC	5	1346610000
UR20-SM-ACC	20	1339920000
PM 2.7/2.6 MC SDR	192	1323700000
PM 2.7/2.6 MC NE WS	960	1323710000
DEK 5/8-11.5 MC SDR	100	1341610000
DEK 5/8-11.5 MC NE WS	500	1341630000
THM UR20 GE *)	1	1429910000
THM UR20 WS *)	1	1429420000
ESD UR20 DIN A4 WS *)	10	1429430000

Replacement parts	
Electronics module	UR20-EM-1315240000-SP 1 1346720000
Basic module	UR20-BM-SP 5 1350930000
Plug-in connector unit	UR20-PK-1315240000-SP 5 1346410000
Note	

*) 1 roll = 1000 label = 1 Qty.
 *) 1 sheet = 60 label = 1 Qty.

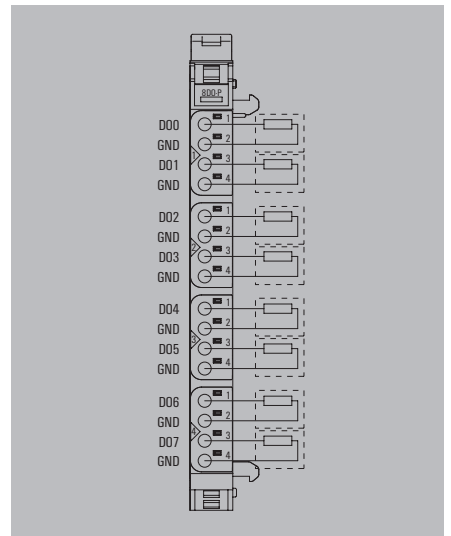

Product standard	IEC 61131-2
EMC	EN 61000
ATEX	EN 60079
UL	UL 508



Let's connect.

16DO-P

- 16 digital outputs
- Can be loaded up to 0.5 A per channel
- Short-circuit-proof
- 1-wire connection
- Positive switching
- DC-13 load
- IEC 61131-2 compliant

UR20-16DO-P



Technical data

System data	
Interface	u-remote system bus
Transmission rate of system bus	48 Mbit/s
Galvanic isolation	yes, DC 500 V between current paths
Supply	
Voltage supply	24 V DC +20 % / - 15 % via the system bus
Current consumption (I _{IN} in power segment of field bus coupler), typ.	8 mA
Current consumption (I _{OUT} in the respective power segment)	20 mA + load
Digital outputs	
Number	16
Type of load	ohmic, inductive, lamp load
Response time, high	100 µs
Response time, low	250 µs
Output current per channel, max.	0.5 A
Output current per module, max.	8 A
Switching frequency max.	1 kHz
	*)
	1 kHz
Actuator connection	1-wire
Short-circuit-proof	thermal
Non reactive	yes
Module diagnosis	yes
Individual channel diagnosis	no
Shut-down energy (inductive)	150 mJ / channel
Response time of protective circuit (current limitation)	< 100 µs (ambient temperature dependent)
General data	
Weight	83 g
Dimensions (H/W/D)	120 mm (with catch lever 128 mm) x 11,5 mm x 76 mm

Ordering data

Module variants	
Digital output module, 16 channels	

Type	Qty.	Order No.
UR20-16DO-P	1	1315250000

*) For this and additional technical data, please refer to the manual available at www.weidmueller.de or scan the QR code below.

Accessories

Coding elements	
Termination kit	
Swivel marker	
Connection marker for pusher custom printing	
Connection marker for pusher neutral	
Module marker for custom printing	
Module marker for neutral	
Thermotransfer version (Material: Polyester)	
Thermotransfer version (Material: Polyester)	
Paper version for Laserprinter	

Type	Qty.	Order No.
KOSM BHZ5 00	100	1483050000
UR20-EBK-ACC	5	1346610000
UR20-SM-ACC	20	1339920000
PM 2.7/2.6 MC SDR	192	1323700000
PM 2.7/2.6 MC NE WS	960	1323710000
DEK 5/8-11.5 MC SDR	100	1341610000
DEK 5/8-11.5 MC NE WS	500	1341630000
THM UR20 GE *)	1	1429910000
THM UR20 WS *)	1	1429420000
ESD UR20 DIN A4 WS *)	10	1429430000

Replacement parts	
Electronics module	UR20-EM-1315250000-SP
Basic module	UR20-BM-SP
Plug-in connector unit	UR20-PK-1315250000-SP

Note

UR20-EM-1315250000-SP	1	1346730000
UR20-BM-SP	5	1350930000
UR20-PK-1315250000-SP	5	1483990000

*) 1 roll = 1000 label = 1 Qty.
*) 1 sheet = 60 label = 1 Qty.

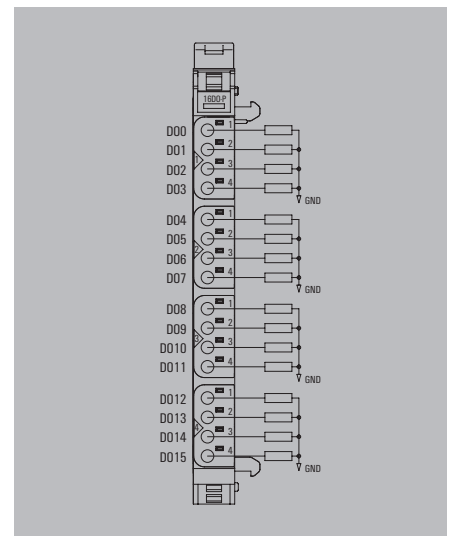

Product standard	IEC 61131-2
EMC	EN 61000
ATEX	EN 60079
UL	UL 508



Let's connect.

16DO-P-PLC-INT

- 16 digital outputs
- Can be loaded up to 0.5 A per channel
- Short-circuit-proof
- For connecting a PLC interface element
- Positive switching
- DC-13 load
- IEC 61131-2 compliant

UR20-16DO-P-PLC-INT



Technical data

System data	
Interface	u-remote system bus
Transmission rate of system bus	48 Mbit/s
Galvanic isolation	yes, DC 500 V between current paths
Supply	
Voltage supply	24 V DC +20 % / - 15 % via the system bus
Current consumption (I _{IN} in power segment of field bus coupler), typ.	8 mA
Current consumption (I _{OUT} external)	20 mA + load
Digital outputs	
Number	16
Type of load	ohmic, inductive, lamp load
Response time, high	100 µs
Response time, low	250 µs
Output current per channel, max.	0.5 A
Output current per module, max.	8 A (2 A with supply via a flat ribbon cable)
Switching frequency max.	1 kHz
	*)
	1 kHz
Actuator connection	PLC interface
Short-circuit-proof	thermal
Non reactive	yes
Module diagnosis	yes
Individual channel diagnosis	no
Shut-down energy (inductive)	150 mJ / channel
Response time of protective circuit (current limitation)	< 100 µs (ambient temperature dependent)
General data	
Weight	82 g
Dimensions (H/W/D)	120 mm (with catch lever 128 mm) x 11,5 mm x 76 mm

Ordering data

Module variants	
Digital output module, 16 channels, PLC interface	

Type	Qty.	Order No.
UR20-16DO-P-PLC-INT	1	1315270000

*) For this and additional technical data, please refer to the manual available at www.weidmueller.de or scan the QR code below.

Accessories

Coding elements	
Termination kit	
Swivel marker	
Connection marker for pusher custom printing	
Connection marker for pusher neutral	
Module marker for custom printing	
Module marker for neutral	
Thermotransfer version (Material: Polyester)	
Thermotransfer version (Material: Polyester)	
Paper version for Laserprinter	
Replacement parts	
Electronics module	
Basic module	
Plug-in connector unit	
PLC interface element	
Pre-assembled cable, 1m	
Note	

Type	Qty.	Order No.
KOSM BHZ5 00	100	1483050000
UR20-EBK-ACC	5	1346610000
UR20-SM-ACC	20	1339920000
PM 2.7/2.6 MC SDR	192	1323700000
PM 2.7/2.6 MC NE WS	960	1323710000
DEK 5/8-11.5 MC SDR	100	1341610000
DEK 5/8-11.5 MC NE WS	500	1341630000
THM UR20 GE *)	1	1429910000
THM UR20 WS *)	1	1429420000
ESD UR20 DIN A4 WS *)	10	1429430000
UR20-EM-1315270000-SP	1	1346740000
UR20-BM-SP	5	1350930000
UR20-PK-1315270000-SP	5	1483940000
RS 16IO 1W H S	1	9445700000
PAC-UNIV-HE20-LCH-1M	1	7789306010

*)1 roll = 1000 label = 1 Qty.
 *)2) 1 sheet = 60 label = 1 Qty.

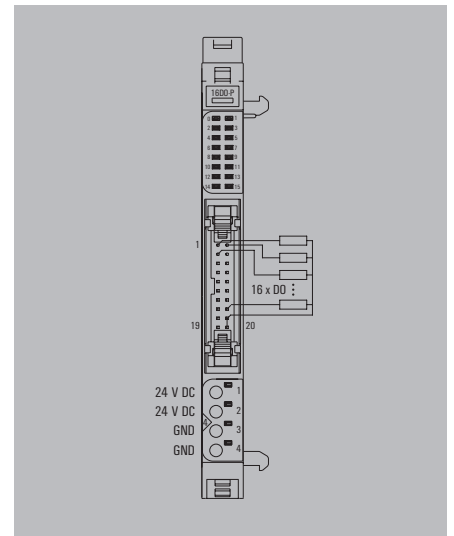

Product standard	IEC 61131-2
EMC	EN 61000
ATEX	EN 60079
UL	UL 508



Let's connect.

4RO-SSR-255

- 4 digital outputs
- Can be loaded up to 0.5 A per channel
- Solid-state relay

UR20-4RO-SSR-255



Technical data

System data	
Interface	u-remote system bus
Transmission rate of system bus	48 Mbit/s
Galvanic isolation	yes, DC 500 V between current paths
Supply	
Voltage supply	24 V DC +20 % / - 15 % via the system bus
Current consumption (I _{IN} in power segment of field bus coupler), typ.	8 mA
Current consumption (I _{OUT} in the respective power segment)	< 15 mA
Digital outputs	
Number	4
Type	SSR /Triac
Response time, high	max. 20 ms, zero-crossing-detection
Response time, low	max. 20 ms, zero-crossing-detection
Output current per channel, max.	0.5 A
Output current per module, max.	2 A
Switching frequency max.	40 Hz
Short-circuit-proof	no
Non reactive	yes
Switching voltage max.	277 V AC ^{*1}
Module diagnosis	yes
Individual channel diagnosis	no
General data	
Weight	83 g
Dimensions (H/W/D)	120 mm (with catch lever) 128 mm) x 11,5 mm x 76 mm

Ordering data

Module variants	
Digital output module, 4 channels, SSR	

Type	Qty.	Order No.
UR20-4RO-SSR-255	1	1315540000

^{*1} For this and additional technical data, please refer to the manual available at www.weidmueller.de or scan the QR code below.

Accessories

Coding elements	
Termination kit	
Swivel marker	
Connection marker for pusher custom printing	
Connection marker for pusher neutral	
Module marker for custom printing	
Module marker for neutral	
Thermotransfer version (Material: Polyester)	
Thermotransfer version (Material: Polyester)	
Paper version for Laserprinter	
Replacement parts	
Electronics module	
Basic module	
Plug-in connector unit	
Note	

Type	Qty.	Order No.
KDSM BHZ5.00	100	1483050000
UR20-EBK-ACC	5	1346610000
UR20-SM-ACC	20	1339920000
PM 2.7/2.6 MC SDR	192	1323700000
PM 2.7/2.6 MC NE WS	960	1323710000
DEK 5/8-11.5 MC SDR	100	1341610000
DEK 5/8-11.5 MC NE WS	500	1341630000
THM UR20 GE ^{*1}	1	1429910000
THM UR20 WS ^{*1}	1	1429420000
ESO UR20 DIN A4 WS ^{*2}	10	1429430000
UR20-EM-1315540000-SP	1	1347120000
UR20-BM-SP	5	1350930000
UR20-PK-1315540000-SP	5	1484000000

^{*1} 1 roll = 1000 label = 1 Qty.
^{*2} 1 sheet = 60 label = 1 Qty.

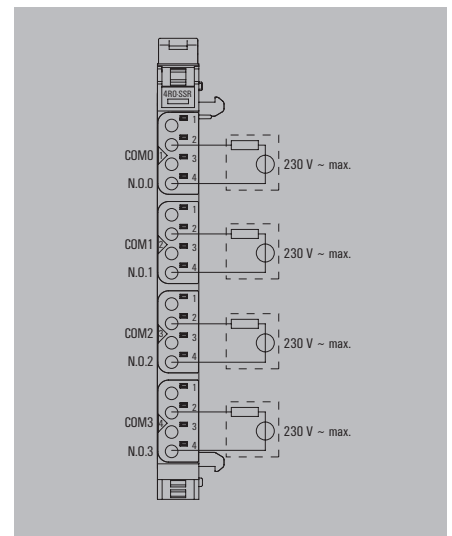

Product standard	IEC 61131-2
EMC	EN 61000
ATEX	EN 60079
UL (in preparation)	UL 508



Let's connect.

4RO-CO-255

- 4 digital outputs
- Can be loaded up to 6 A per channel
- Relay output, change-over contact
- Switching voltage 277 V AC/DC

UR20-4RO-CO-255



Technical data

System data	
Interface	u-remote system bus
Transmission rate of system bus	48 Mbit/s
Galvanic isolation	yes, DC 500 V between current paths
Supply	
Voltage supply	24 V DC +20 % / - 15 % via the system bus
Current consumption (I _{IN} in power segment of field bus coupler), typ.	8 mA
Current consumption (I _{OUT} in the respective power segment)	< 15 mA
Digital outputs	
Number	4
Type	Change-over contact
Response time, high	20 ms
Response time, low	20 ms
Output current per channel, max.	5 A at 60 °C / 6 A at 55 °C
Output current per module, max.	20 A at 60 °C / 24 A at 55 °C
Switching frequency max.	5 Hz
Short-circuit-proof	no
Non reactive	yes
Switching voltage max.	277 V AC/DC *)
Module diagnosis	yes
Individual channel diagnosis	no
General data	
Weight	83 g
Dimensions (H/W/D)	120 mm (with catch lever 128 mm) x 11,5 mm x 76 mm

Ordering data

Module variants	
Digital output module, 4 channels, relay	

Type	Qty.	Order No.
UR20-4RO-CO-255	1	1315550000

*) For this and additional technical data, please refer to the manual available at www.weidmueller.de or scan the QR code below.

Accessories

Accessories	
Coding elements	
Termination kit	
Swivel marker	
Connection marker for pusher custom printing	
Connection marker for pusher neutral	
Module marker for custom printing	
Module marker for neutral	
Thermotransfer version (Material: Polyester)	
Thermotransfer version (Material: Polyester)	
Paper version for Laserprinter	
Replacement parts	
Electronics module	
Basic module	
Plug-in connector unit	
Note	

Type	Qty.	Order No.
KOSM BHZ5.00	100	1483050000
UR20-EBK-ACC	5	1346610000
UR20-SM-ACC	20	1339920000
PM 2.7/2.6 MC SDR	192	1323700000
PM 2.7/2.6 MC NE WS	960	1323710000
DEK 5/8-11.5 MC SDR	100	1341610000
DEK 5/8-11.5 MC NE WS	500	1341630000
THM UR20 GE *)	1	1429910000
THM UR20 WS *)	1	1429420000
ESO UR20 DIN A4 WS *)	10	1429430000
UR20-EM-1315550000-SP	1	1347130000
UR20-BM-SP	5	1350930000
UR20-PK-1315550000-SP	5	1346500000

*)¹ 1 roll = 1000 label = 1 Qty.
 *)² 1 sheet = 60 label = 1 Qty.

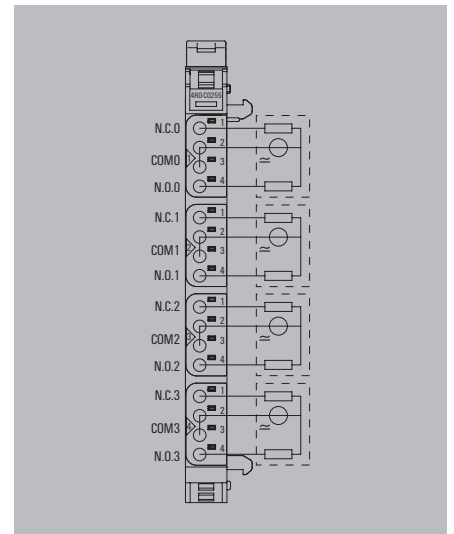

Product standard	IEC 61131-2
EMC	EN 61000
ATEX	EN 60079
UL	UL 508



Let's connect.

Digital counter modules

100 kHz; 32-Bit Counter data width; Single channel diagnosis

IP 20
A

In automated systems, it is impossible to imagine industry without the collection of incremental values.

Developed specifically for these applications Weidmüller now offers two counter modules that can take values with an input frequency of up to 100 kHz.

The 2CNT-100 module has two independent counter inputs and is supplemented by the module 1CNT-100-1DO with only one counter, but additional options. A Latch-, Gate- and Reset input allows external control of the counter. In addition, a digital output can trigger an immediate event, when there are compared values set.

The module electronics supply the connected sensors from the input current path (U_{IN}).

UR20-1CNT-100-1DO block diagram example

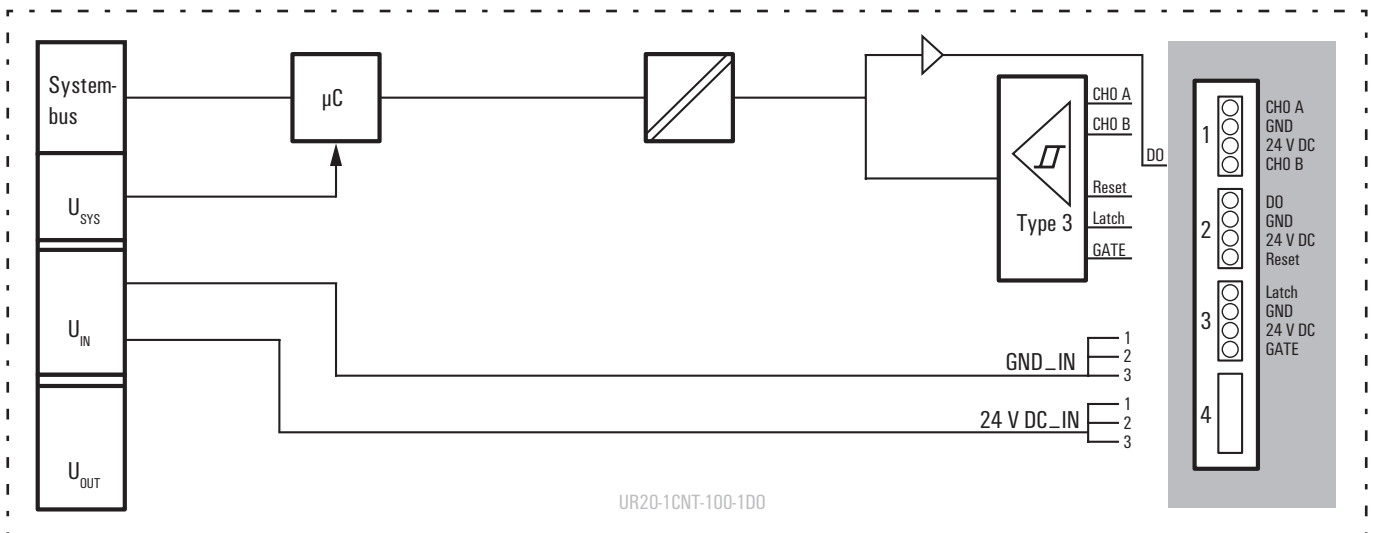

1CNT-100-1D0

- Latch-, Gate- and Reset input
- Counter data width 32-Bit
- Maximum input frequency 100 kHz
- Operation mode impulse, direction, 1-, 2- or 4-times
- Sensor feed
- Input filter adjustable up to 1 ms
- One digital output

UR20-1CNT-100-1D0



Technical data

System data	
Interface	u-remote system bus
Transmission rate of system bus	48 Mbit/s
Galvanic isolation	yes, DC 500 V between current paths
Supply	
Voltage supply	24 V DC +20 % / - 15 % via the system bus
Current consumption (I _N in power segment of field bus coupler), typ.	8 mA
Current consumption (I _N in the respective power segment)	35 mA
Digital Inputs	
Number of counter inputs	1
Type	incremental encoder
Input filter	adjustable up to 1 ms
Input voltage, low	< 5 V
Input voltage, high	> 11 V
Sensor feed	yes
Sensor connection	2- and 3-wire
Reverse polarity protection	yes
Module diagnosis	yes
Single channel diagnosis	no
Input current per channel, max.	3.5 mA
Counter data width	32 Bit
Input frequency, max.	100 kHz
Counter frequency, max.	400 kHz
Latch-, Gate-, Reset-input	yes
Operation mode	Impulse / direction / 1-, 2-, 4-times
General data	
Weight	87 g
Dimensions (H/W/D)	120 mm (with catch lever 128 mm) x 11.5 mm x 76 mm

Type	Qty.	Order No.
UR20-1CNT-100-1D0	1	1315570000

Ordering data

Module variants	
Digital counter module, 1 channel, 100 kHz	

Accessories

Type	Qty.	Order No.
KDSM BHZ5.00	100	1483050000
UR20-EBK-ACC	5	1346610000
UR20-SM-ACC	20	1339920000
PM 2.7/2.6 MC SDR	192	1323700000
PM 2.7/2.6 MC NE WS	960	1323710000
DEK 5/8-11.5 MC SDR	100	1341610000
DEK 5/8-11.5 MC NE WS	500	1341630000
THM UR20 GE *1)	1	1429910000
THM UR20 WS *1)	1	1429420000
ESO UR20 DIN A4 WS *2)	10	1429430000
UR20-EM-1315570000-SP	1	1347140000
UR20-BM-SP	5	1350930000
UR20-PK-1315570000-SP	5	1346520000

*1) 1 roll = 1000 label = 1 Qty.
*2) 1 sheet = 60 label = 1 Qty.

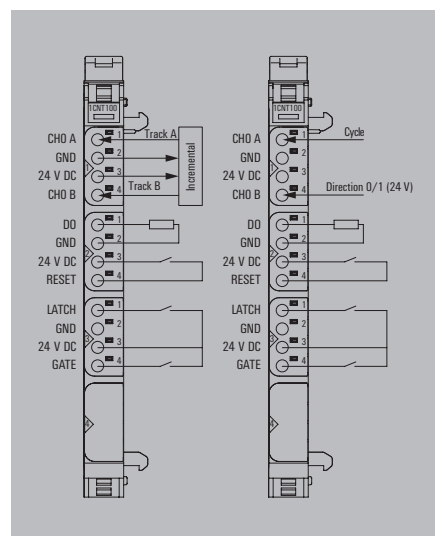

Product standard	IEC 61131-2
EMC	EN 61000
ATEX	EN 60079
UL (in preparation)	UL 508



Let's connect.

2CNT-100

- Counter data width 32 Bit
- Maximum input frequency 100 kHz
- Operation mode impulse, direction, 1-, 2- or 4-times
- Sensor feed
- Input filter adjustable up to 1 ms

UR20-2CNT-100



Technical data

System data	
Interface	u-remote system bus
Transmission rate of system bus	48 Mbit/s
Galvanic isolation	yes, DC 500 V between current paths
Supply	
Voltage supply	24 V DC +20 % / - 15 % via the system bus
Current consumption (I _N in power segment of field bus coupler), typ.	8 mA
Current consumption (I _N in the respective power segment)	35 mA
Digital Inputs	
Number of counter inputs	2
Type	incremental encoder
Input filter	adjustable up to 1 ms
Input voltage, low	< 5 V
Input voltage, high	> 11 V
Sensor feed	yes
Sensor connection	2- and 3-wire
Reverse polarity protection	yes
Module diagnosis	yes
Single channel diagnosis	no
Input current per channel, max.	3 mA
Counter data width	32 Bit
Input frequency, max.	100 kHz
Counter frequency, max.	400 kHz
Operation mode	Impulse / direction / 1-, 2-, 4-times
General data	
Weight	87 g
Dimensions (H/W/D)	120 mm (with catch lever 128 mm) x 11.5 mm x 76 mm

Type	Qty.	Order No.
UR20-2CNT-100	1	1315590000

Ordering data

Module variants	
Digital counter module, 2 channel, 100 kHz	

Accessories

Type	Qty.	Order No.
KOSM BHZ5.00	100	1483050000
UR20-EBK-ACC	5	1346610000
UR20-SM-ACC	20	1339920000
PM 2.7/2.6 MC SDR	192	1323700000
PM 2.7/2.6 MC NE WS	960	1323710000
DEK 5/8-11.5 MC SDR	100	1341610000
DEK 5/8-11.5 MC NE WS	500	1341630000
THM UR20 GE * ¹⁾	1	1429910000
THM UR20 WS * ¹⁾	1	1429420000
ESD UR20 DIN A4 WS * ²⁾	10	1429430000
Replacement parts		
UR20-EM-1315590000-SP	1	1347150000
UR20-BM-SP	5	1350930000
UR20-PK-1315590000-SP	5	1346540000
* ¹⁾ 1 roll = 1000 label = 1 Qty. * ²⁾ 1 sheet = 60 label = 1 Qty.		

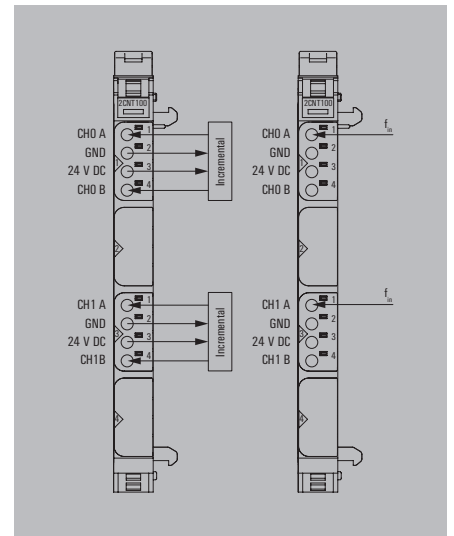

Product standard	IEC 61131-2
EMC	EN 61000
ATEX	EN 60079
UL (in preparation)	UL 508



Let's connect.

2FCNT-100

- Counter data width 32 Bit
- Maximum input frequency 100 kHz
- Operation mode impulse
- Sensor feed
- Input filter adjustable up to 1 ms

UR20-2FCNT-100



Technical data

System data	
Interface	u-remote system bus
Transmission rate of system bus	48 Mbit/s
Galvanic isolation	yes, DC 500 V between current paths
Supply	
Voltage supply	24 V DC +20 % / - 15 % via the system bus
Current consumption (I _N in power segment of field bus coupler), typ.	8 mA
Current consumption (I _N in the respective power segment)	35 mA
Digital Inputs	
Number of counter inputs	2
Type	digital input
Input filter	adjustable up to 1 ms
Input voltage, low	< 5 V
Input voltage, high	> 11 V
Sensor feed	yes
Sensor connection	2- and 3-wire
Reverse polarity protection	yes
Module diagnosis	yes
Single channel diagnosis	no
Input current per channel, max.	3 mA
Counter data width	32 Bit
Input frequency, max.	100 kHz
Operation mode	Impulse
General data	
Weight	87 g
Dimensions (H/W/D)	120 mm (with catch lever 128 mm) x 11.5 mm x 76 mm

Ordering data

Module variants
Digital frequency counter module, 2 channel, 100 kHz

Type	Qty.	Order No.
UR20-2FCNT-100	1	1508080000

Accessories

Coding elements	KDSM BHZ5.00	100	1483050000
Termination kit	UR20-EBK-ACC	5	1346610000
Swivel marker	UR20-SM-ACC	20	1339920000
Connection marker for pusher custom printing	PM 2.7/2.6 MC SDR	192	1323700000
Connection marker for pusher neutral	PM 2.7/2.6 MC NE WS	960	1323710000
Module marker for custom printing	DEK 5/8-11.5 MC SDR	100	1341610000
Module marker for neutral	DEK 5/8-11.5 MC NE WS	500	1341630000
Thermotransfer version (Material: Polyester)	THM UR20 GE * ¹⁾	1	1429910000
Thermotransfer version (Material: Polyester)	THM UR20 WS * ¹⁾	1	1429420000
Paper version for Laserprinter	ESO UR20 DIN A4 WS * ²⁾	10	1429430000
Replacement parts			
Electronics module	UR20-EM-1508080000-SP	1	1515440000
Basic module	UR20-BM-1508080000-SP	5	1350930000
Plug-in connector unit	UR20-PK-1508080000-SP	5	1518840000
Note			

* ¹⁾ 1 roll = 1000 label = 1 Qty.
* ²⁾ 1 sheet = 60 label = 1 Qty.

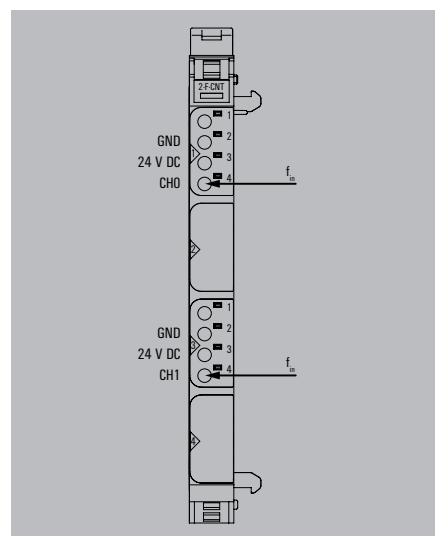

Product standard	IEC 61131-2
EMC	EN 61000
ATEX	EN 60079
UL (in preparation)	UL 508



Let's connect.

Pulse width modulation modules

Frequency can be adjusted up to 40 kHz;
short-circuit-proof; two PWM outputs

As part of the new u-remote system, Weidmüller provides a specialised solution for controlling small motors with current requirements of 0.5 A to 2 A which can also be used to control valve flaps. Here, not only can the switching frequencies be set up to 40 kHz, the push/pull output levels can also be used for motor activation, for example, to change direction of rotation. As with all modules in the u-remote system, the characteristics are outstanding – from the modular design and interchangeable electronics to the removable and plug-in terminal strip.

The module electronics supply the connected actuators from the output current path (U_{OUT}).

UR20-2PWM-PN-0.5A block diagram example

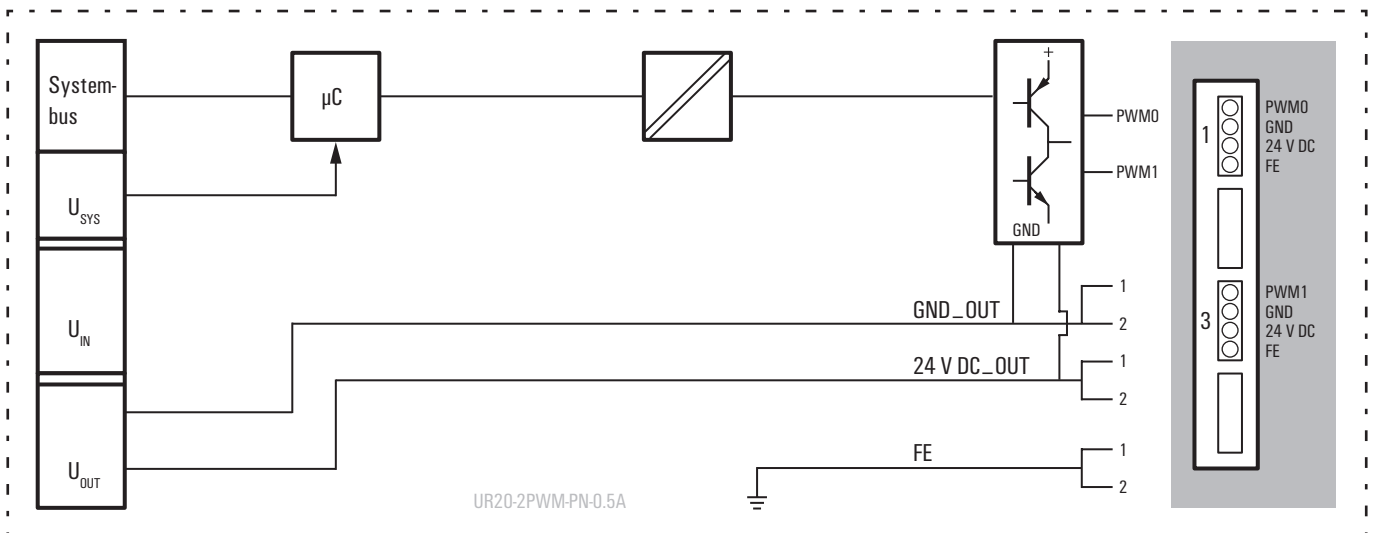

2PWM-PN-0.5A

- 2 pulse width modulation module outputs
- Can be loaded up to 0.5 A per channel
- Short-circuit-proof
- Push/pull output
- Maximum 40 kHz output frequency (adjustable)

UR20-2PWM-PN-0.5A**Technical data**

System data	
Interface	u-remote system bus
Transmission rate of system bus	48 Mbit/s
Galvanic isolation	yes, DC 500 V between current paths
Supply	
Voltage supply	24 V DC +20 % / - 15 % via the system bus
Current consumption (I_{in} in power segment of field bus coupler), typ.	8 mA
Current consumption (I_{out} in the respective power segment)	40 mA + Load
Digital outputs	
Number	2
Type	PWM push/pull output stage
Resolution	32 Bit
Accuracy	1 Bit
Response time, high	< 100 ns
Response time, low	< 100 ns
Output current per channel, max.	0.5 A
Output current per module, max.	1 A
Switching frequency max.	
Resistive load (min. 47 Ω)	static, 6 Hz to 40 kHz
Inductive load (DC 13)	static, 6 Hz to 40 kHz
Lamp load (12 W)	static, 6 Hz to 40 kHz
Actuator connection	yes
Short-circuit-proof	yes
Module diagnosis	yes
Individual channel diagnosis	no
Non reactive	yes
Pulse duty factor	0 - 100 % push/pull or push parameterisable
General data	
Weight	77 g
Dimensions (H/W/D)	120 mm (with catch lever) 128 mm x 11,5 mm x 76 mm

Ordering data

Module variants
Digital output module, PWM, 2 channels, 0.5 A

Type	Qty.	Order No.
UR20-2PWM-PN-0.5A	1	131560000

Accessories

Coding elements	
Termination kit	
Swivel marker	
Connection marker for pusher custom printing	
Connection marker for pusher neutral	
Module marker for custom printing	
Module marker for neutral	
Thermotransfer version (Material: Polyester)	
Thermotransfer version (Material: Polyester)	
Paper version for Laserprinter	
Replacement parts	
Electronics module	
Basic module	
Plug-in connector unit	
Note	

Type	Qty.	Order No.
KDSM BHZ5.00	100	1483050000
UR20-EBK-ACC	5	1346610000
UR20-SM-ACC	20	1339920000
PM 2.7/2.6 MC SDR	192	1323700000
PM 2.7/2.6 MC NE WS	960	1323710000
DEK 5/8-11.5 MC SDR	100	1341610000
DEK 5/8-11.5 MC NE WS	500	1341630000
THM UR20 GE ^{*1)}	1	1429910000
THM UR20 WS ^{*1)}	1	1429420000
ESO UR20 DIN A4 WS ^{*2)}	10	1429430000
UR20-EM-1315600000-SP	1	1347180000
UR20-BM-SP	5	1350930000
UR20-PK-1315600000-SP	5	1484010000

^{*1)} 1 roll = 1000 label = 1 Qty.
^{*2)} 1 sheet = 60 label = 1 Qty.

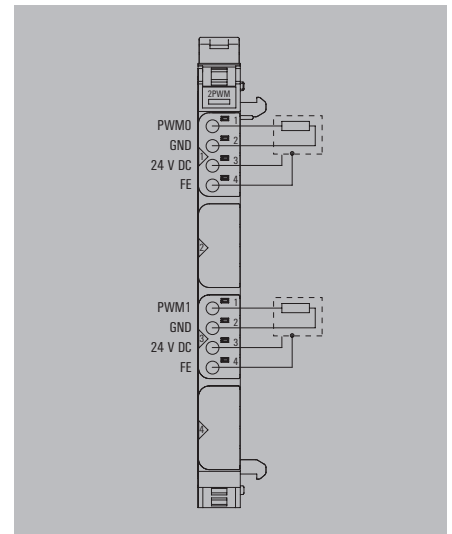

Product standard	IEC 61131-2
EMC	EN 61000
ATEX	EN 60079
UL (in preparation)	UL 508



Let's connect.

2PWM-PN-2A

- 2 pulse width modulation module outputs
- Can be loaded up to 2 A per channel
- Short-circuit-proof
- Push/pull output
- Maximum 40 kHz output frequency (adjustable)

UR20-2PWM-PN-2A



Technical data

System data	
Interface	u-remote system bus
Transmission rate of system bus	48 Mbit/s
Galvanic isolation	yes, DC 500 V between current paths
Supply	
Voltage supply	24 V DC +20 % / - 15 % via the system bus
Current consumption (I _{in} in power segment of field bus coupler), typ.	8 mA
Current consumption (I _{out} in the respective power segment)	40 mA + Load
Digital outputs	
Number	2
Type	PWM push/pull output stage
Resolution	32 Bit
Accuracy	1 Bit
Response time, high	< 100 ns
Response time, low	< 100 ns
Output current per channel, max.	2 A
Output current per module, max.	4 A
Switching frequency max.	
Resistive load (min. 47 Ω)	static, 6 Hz to 40 kHz
Inductive load (DC 13)	static, 6 Hz to 40 kHz
Lamp load (12 W)	static, 6 Hz to 40 kHz
Actuator connection	yes
Short-circuit-proof	yes
Module diagnosis	yes
Individual channel diagnosis	no
Non reactive	yes
Pulse duty factor	0 - 100 % push/pull or push parameterisable
General data	
Weight	82 g
Dimensions (H/W/D)	120 mm (with catch lever) 128 mm x 11,5 mm x 76 mm

Ordering data

Module variants	
Digital output module, PWM, 2 channels, 2 A	

Type	Qty.	Order No.
UR20-2PWM-PN-2A	1	1315610000

Accessories

Coding elements	
Termination kit	
Swivel marker	
Connection marker for pusher custom printing	
Connection marker for pusher neutral	
Module marker for custom printing	
Module marker for neutral	
Thermotransfer version (Material: Polyester)	
Thermotransfer version (Material: Polyester)	
Paper version for Laserprinter	
Replacement parts	
Electronics module	
Basic module	
Plug-in connector unit	
Note	

Type	Qty.	Order No.
KDSM BHZ5.00	100	1483050000
UR20-EBK-ACC	5	1346610000
UR20-SM-ACC	20	1339920000
PM 2.7/2.6 MC SDR	192	1323700000
PM 2.7/2.6 MC NE WS	960	1323710000
DEK 5/8-11.5 MC SDR	100	1341610000
DEK 5/8-11.5 MC NE WS	500	1341630000
THM UR20 GE ^{*1)}	1	1429910000
THM UR20 WS ^{*1)}	1	1429420000
ESO UR20 DIN A4 WS ^{*2)}	10	1429430000
UR20-EM-1315610000-SP	1	1347190000
UR20-BM-SP	5	1350930000
UR20-PK-1315610000-SP	5	1346550000

^{*1)} 1 roll = 1000 label = 1 Qty.
^{*2)} 1 sheet = 60 label = 1 Qty.

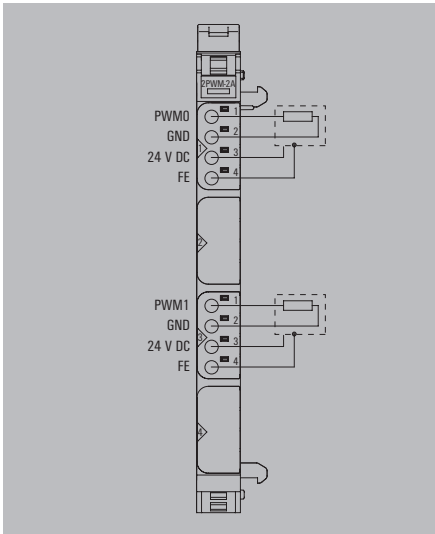

Product standard	IEC 61131-2
EMC	EN 61000
ATEX	EN 60079
UL (in preparation)	UL 508



Let's connect.

Analogue input modules

Input parameters can be set for current or voltage; up to 3-wire+FE; Accuracy 0.1% FSR

Analogue input modules of the u-remote system are available in many variants with different resolutions and wiring solutions.

Variants are available in a 12- and 16-bit resolution, which record up to 4 analogue sensors with +/-10 V, +/-5 V, 0...10 V, 0...5 V, 2...10 V, 1...5 V, 0...20 mA or 4...20 mA with maximum accuracy. Each plug-in connector has options for connecting sensors with 2-wire, 3-wire and 3-wire+FE technology. The parameters for the measurement range can be individually set for each channel. A separate status LED is also assigned to each channel.

A special variant for Weidmüller interface units enables current measurements with a 16-bit resolution at maximum accuracy for 8 sensors at a time (0...20 mA or 4...20 mA).

The module electronics supply the connected sensors from the input current path (U_{IN}).

UR20-4AI-UI-16 block diagram example

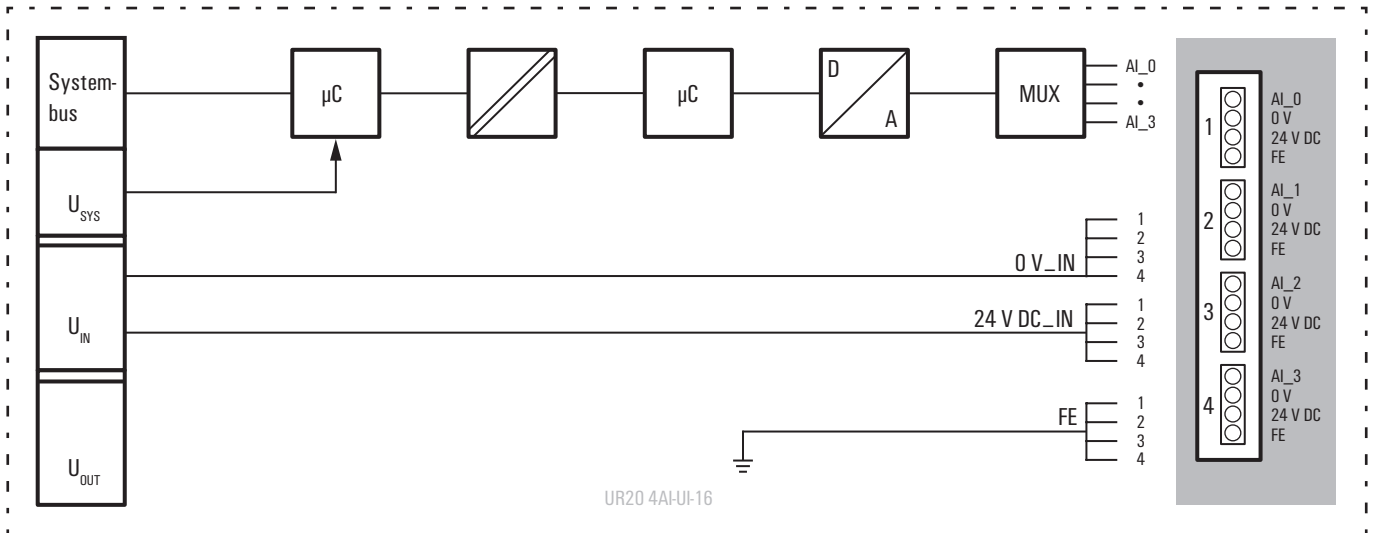

4AI-UI-16

- 4 analogue inputs
- Parameterisable inputs (voltage, current)
- 16-bit resolution
- 2-wire, 3-wire and 3-wire+FE connection
- Accuracy 0.1 % FSR

UR20-4AI-UI-16



Technical data

System data	
Interface	u-remote system bus
Transmission rate of system bus	48 Mbit/s
Galvanic isolation	yes, DC 500 V between current paths
Supply	
Voltage supply	24 V DC +20 % / -15 % via the system bus
Current consumption (I _N in power segment of field bus coupler), typ.	8 mA
Current consumption (I _N in the respective power segment)	25 mA + sensor feed
Analogue inputs	
Number	4
Input	1. Voltage (0...5 V, ±5 V, 0...10 V, ±10 V, 1...5 V, 2...10 V) 2. Current (0...20 mA, 4...20 mA)
Resolution	16 Bit
Accuracy	0.1 % FSR
Sensor supply	yes
Sensor connection	2-wire, 3-wire, 3-wire+FE
Conversion time	1 ms
Internal resistance U	100 kΩ
Internal resistance I	41.2 Ω
Reverse polarity protection	yes
Module diagnosis	yes
Individual channel diagnosis	no
Short-circuit-proof	yes
General data	
Weight	89 g
Dimensions (H/W/D)	120 mm (with catch lever 128 mm) x 11,5 mm x 76 mm

Ordering data

Module variants	
Analogue input module, 4 channels, 16 bits	

Type	Qty.	Order No.
UR20-4AI-UI-16	1	1315620000

Accessories

Replacement parts	
Electronics module	UR20-EM-1315620000-SP
Basic module	UR20-BM-SP
Plug-in connector unit	UR20-PK-1315620000-SP
Note	

Type	Qty.	Order No.
KDSM BHZ5.00	100	1483050000
UR20-EBK-ACC	5	1346610000
UR20-SM-ACC	20	1339920000
PM 2.7/2.6 MC SDR	192	1323700000
PM 2.7/2.6 MC NE WS	960	1323710000
DEK 5/8-11.5 MC SDR	100	1341610000
DEK 5/8-11.5 MC NE WS	500	1341630000
THM UR20 GE * ¹⁾	1	1429910000
THM UR20 WS * ¹⁾	1	1429420000
ESO UR20 DIN A4 WS * ²⁾	10	1429430000

*¹⁾ 1 roll = 1000 label = 1 Qty.
*²⁾ 1 sheet = 60 label = 1 Qty.

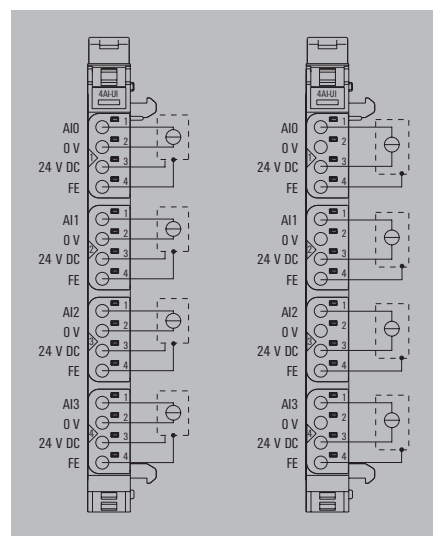

Product standard	IEC 61131-2
EMC	EN 61000
ATEX	EN 60079
UL	UL 508



Let's connect.

4AI-UI-16-DIAG

- Advanced diagnosis functions
- 4 analogue inputs
- Parameterisable inputs (voltage, current)
- 16-bit resolution
- 2-wire, 3-wire and 3-wire+FE connection
- Accuracy 0.1 % FSR

UR20-4AI-UI-16-DIAG



Technical data

System data	
Interface	u-remote system bus
Transmission rate of system bus	48 Mbit/s
Galvanic isolation	yes, DC 500 V between current paths
Supply	
Voltage supply	24 V DC +20 % / -15 % via the system bus
Current consumption (I _N in power segment of field bus coupler), typ.	8 mA
Current consumption (I _N in the respective power segment)	25 mA + sensor feed
Analogue inputs	
Number	4
Input	1. Voltage (0...5 V, ±5 V, 0...10 V, ±10 V, 1...5 V, 2...10 V) 2. Current (0...20 mA, 4...20 mA)
Resolution	16 Bit
Accuracy	0.1 % FSR
Sensor supply	yes
Sensor connection	2-wire, 3-wire, 3-wire+FE
Conversion time	1 ms
Internal resistance U	100 kΩ
Internal resistance I	approx. 45 Ω
Reverse polarity protection	yes
Module diagnosis	yes
Individual channel diagnosis	yes
Short-circuit-proof	yes
General data	
Weight	89 g
Dimensions (H/W/D)	120 mm (with catch lever 128 mm) x 11,5 mm x 76 mm

Type	Qty.	Order No.
UR20-4AI-UI-16-DIAG	1	1315690000

Ordering data

Module variants	
Analogue input module, 4 channels, 16 bits, diagnosis functions	

Accessories

Coding elements	KDSM BHZ5.00	100	1483050000
Termination kit	UR20-EBK-ACC	5	1346610000
Swivel marker	UR20-SM-ACC	20	1339920000
Connection marker for pusher custom printing	PM 2.7/2.6 MC SDR	192	1323700000
Connection marker for pusher neutral	PM 2.7/2.6 MC NE WS	960	1323710000
Module marker for custom printing	DEK 5/8-11.5 MC SDR	100	1341610000
Module marker for neutral	DEK 5/8-11.5 MC NE WS	500	1341630000
Thermotransfer version (Material: Polyester)	THM UR20 GE * ¹⁾	1	1429910000
Thermotransfer version (Material: Polyester)	THM UR20 WS * ¹⁾	1	1429420000
Paper version for Laserprinter	ESO UR20 DIN A4 WS * ²⁾	10	1429430000
Replacement parts			
Electronics module	UR20-EM-1315690000-SP	1	1347280000
Basic module	UR20-BM-1315690000-SP	5	1350930000
Plug-in connector unit	UR20-PK-1315690000-SP	5	1518870000
Note			
* ¹⁾ 1 roll = 1000 label = 1 Qty.			
* ²⁾ 1 sheet = 60 label = 1 Qty.			

Product standard	IEC 61131-2
EMC	EN 61000
ATEX	EN 60079
UL (in preparation)	UL 508

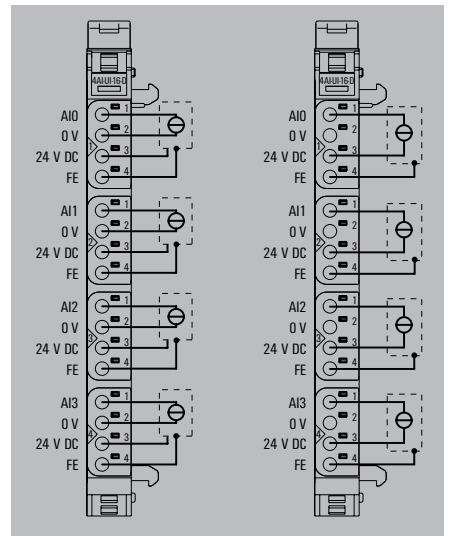

Let's connect.

4AI-UI-16-HD

- 4 plugs with 4 connections per module
- 4 analogue inputs
- Parameterisable inputs (voltage, current)
- 16-bit resolution
- 2-wire, 3-wire and 3-wire+FE connection
- Accuracy 0.1 % FSR

UR20-4AI-UI-16-HD

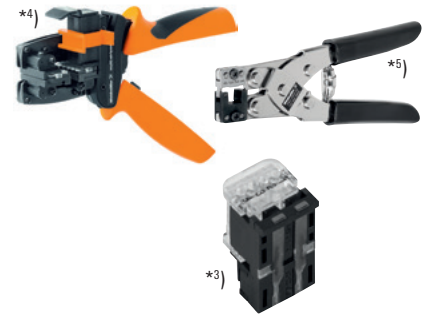

Note: Please order connector separately

Technical data

System data	
Interface	u-remote system bus
Transmission rate of system bus	48 Mbit/s
Galvanic isolation	yes, DC 500 V between current paths
Supply	
Voltage supply	24 V DC +20 % / -15 % via the system bus
Current consumption (I _N in power segment of field bus coupler), typ.	8 mA
Current consumption (I _N in the respective power segment)	25 mA + sensor feed
Analogue inputs	
Number	4
Input	1. Voltage (0...5 V, ±5 V, 0...10 V, ±10 V, 1...5 V, 2...10 V) 2. Current (0...20 mA, 4...20 mA)
Resolution	16 Bit
Accuracy	0.1 % FSR
Sensor supply	yes
Sensor connection	2-wire, 3-wire, 3-wire+FE
Conversion time	1 ms
Internal resistance U	100 kΩ
Internal resistance I	approx. 45 Ω
Reverse polarity protection	yes
Module diagnosis	yes
Individual channel diagnosis	no
Short-circuit-proof	yes
General data	
Weight	89 g
Dimensions (H/W/D)	120 mm (with catch lever 128 mm) x 11,5 mm x 76 mm

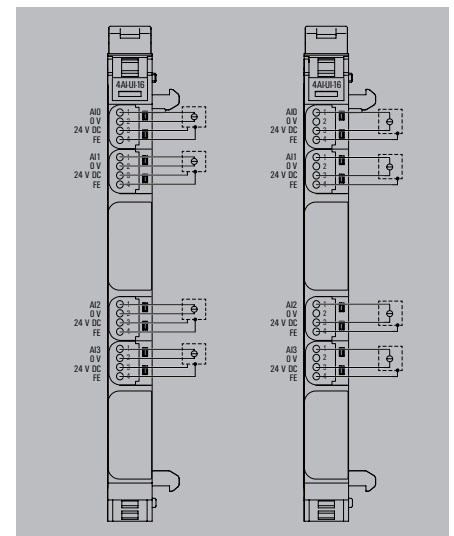

Ordering data

Module variants	Type	Qty.	Order No.
Analogue input module, 4 channels, 16 bits, HD plug	UR20-4AI-UI-16-HD	1	1506920000

Accessories

	Type	Qty.	Order No.
Coding elements	KDSM BHZ5.00	100	1483050000
Termination kit	UR20-EBK-ACC	5	1346610000
Swivel marker	UR20-SM-ACC	20	1339920000
*3) HD-Plug	UR20-PGO.35	8	1469340000
*4) Stripping tool	multi-stripax 6-16	1	9202210000
*5) Pressing tool	PWZ-UR20-HD	1	1525820000
Module marker for custom printing	DEK 5/8-11.5 MC SDR	100	1341610000
Module marker for neutral	DEK 5/8-11.5 MC NE WS	500	1341630000
Thermotransfer version (Material: Polyester)	THM UR20 GE *1)	1	1429910000
Thermotransfer version (Material: Polyester)	THM UR20 WS *1)	1	1429420000
Paper version for Laserprinter	ESD UR20 DIN A4 WS *2)	10	1429430000
Replacement parts			
Electronics module	UR20-EM-1506920000-SP	1	1515420000
Basic module	UR20-BM-1506920000-SP	5	1350930000
Plug-in connector unit	UR20-PK-1506920000-SP	5	1518830000

*1) 1 roll = 1000 label = 1 Qty.
*2) 1 sheet = 60 label = 1 Qty.

Product standard	IEC 61131-2
EMC	EN 61000
ATEX	EN 60079
UL (in preparation)	UL 508



Let's connect.

4AI-UI-16-DIAG-HD

- 4 plugs with 4 connections per module
- Advanced diagnosis functions
- 4 analogue inputs
- Parameterisable inputs (voltage, current)
- 16-bit resolution
- 2-wire, 3-wire and 3-wire+FE connection
- Accuracy 0.1 % FSR

UR20-4AI-UI-16-DIAG-HD

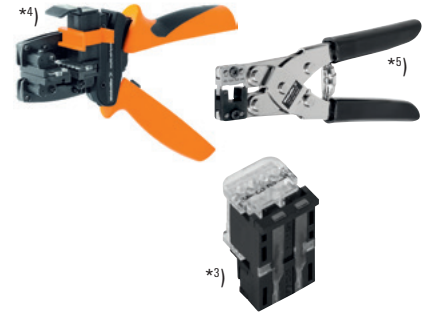

Note: Please order connector separately

Technical data

System data

Interface
Transmission rate of system bus
Galvanic isolation

Supply

Voltage supply
Current consumption (I_N in power segment of field bus coupler), typ.
Current consumption (I_N in the respective power segment)

Analogue inputs

Number
Input

Resolution
Accuracy
Sensor supply
Sensor connection
Conversion time
Internal resistance U
Internal resistance I
Reverse polarity protection
Module diagnosis
Individual channel diagnosis
Short-circuit-proof

General data

Weight
Dimensions (H/W/D)

u-remote system bus
48 Mbit/s
yes, DC 500 V between current paths
24 V DC +20 % / -15 % via the system bus
8 mA
25 mA + sensor feed
4
1. Voltage (0...5 V, ±5 V, 0...10 V, ±10 V, 1...5 V, 2...10 V)
2. Current (0...20 mA, 4...20 mA)
16 Bit
0.1 % FSR
yes
2-wire, 3-wire, 3-wire+FE
1 ms
100 kΩ
approx. 45 Ω
yes
yes
yes
yes

Ordering data

Module variants

Analogue input module, 4 channels, 16 bits, diagnosis functions, HD plug

Type	Qty.	Order No.
UR20-4AI-UI-16-DIAG-HD	1	1506910000

Accessories

- Coding elements
- Termination kit
- Swivel marker
- *3) HD-Plug
- *4) Stripping tool
- *5) Pressing tool
- Module marker for custom printing
- Module marker for neutral
- Thermotransfer version (Material: Polyester)
- Thermotransfer version (Material: Polyester)
- Paper version for Laserprinter

Type	Qty.	Order No.
KOSM BHZ5.00	100	1483050000
UR20-EBK-ACC	5	1346610000
UR20-SM-ACC	20	1339920000
UR20-PGO.35	8	1469340000
multi-stripax 6-16	1	9202210000
PWZ-UR20-HD	1	1525820000
DEK 5/8-11.5 MC SDR	100	1341610000
DEK 5/8-11.5 MC NE WS	500	1341630000
THM UR20 GE *1)	1	1429910000
THM UR20 WS *1)	1	1429420000
ESO UR20 DIN A4 WS *2)	10	1429430000

Replacement parts

Electronics module
Basic module
Plug-in connector unit

UR20-EM-1506910000-SP	1	1515430000
UR20-BM-1506910000-SP	5	1350930000
UR20-PK-1506910000-SP	5	1518820000

*1) 1 roll = 1000 label = 1 Qty.
*2) 1 sheet = 60 label = 1 Qty.

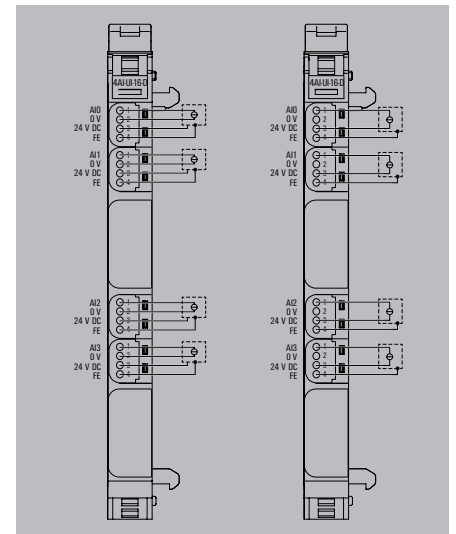

Product standard	IEC 61131-2
EMC	EN 61000
ATEX	EN 60079
UL (in preparation)	UL 508



Let's connect.

4AI-UI-12

- 4 analogue inputs
- Parameterisable inputs (voltage, current)
- 12-bit resolution
- 2-wire, 3-wire and 3-wire+FE connection
- Accuracy 0.25 % FSR

UR20-4AI-UI-12



Technical data

System data	
Interface	u-remote system bus
Transmission rate of system bus	48 Mbit/s
Galvanic isolation	yes, DC 500 V between current paths
Supply	
Voltage supply	24 V DC +20 % / - 15 % via the system bus
Current consumption (I _N in power segment of field bus coupler), typ.	8 mA
Current consumption (I _N in the respective power segment)	25 mA + sensor feed
Analogue inputs	
Number	4
Input	1. Voltage (0...5 V, ±5 V, 0...10 V, ±10 V, 1...5 V, 2...10 V) 2. Current (0...20 mA, 4...20 mA)
Resolution	12 Bit
Accuracy	0,25 % FSR
Sensor supply	yes
Sensor connection	2-wire, 3-wire, 3-wire+FE
Conversion time	1 ms
Internal resistance U	100 kΩ
Internal resistance I	41.2 Ω
Reverse polarity protection	yes
Module diagnosis	yes
Individual channel diagnosis	no
Short-circuit-proof	yes
General data	
Weight	87 g
Dimensions (H/W/D)	120 mm (with catch lever) 128 mm x 11,5 mm x 76 mm

Ordering data

Module variants	
Analogue input module, 4 channels, 12 bits	

Type	Qty.	Order No.
UR20-4AI-UI-12	1	1394390000

Accessories

Replacement parts	
Electronics module	UR20-EM-1394390000-SP
Basic module	UR20-BM-SP
Plug-in connector unit	UR20-PK-1394390000-SP
Note	

Type	Qty.	Order No.
KDSM BHZ5.00	100	1483050000
UR20-EBK-ACC	5	1346610000
UR20-SM-ACC	20	1339920000
PM 2.7/2.6 MC SDR	192	1323700000
PM 2.7/2.6 MC NE WS	960	1323710000
DEK 5/8-11.5 MC SDR	100	1341610000
DEK 5/8-11.5 MC NE WS	500	1341630000
THM UR20 GE * ¹⁾	1	1429910000
THM UR20 WS * ¹⁾	1	1429420000
ESO UR20 DIN A4 WS * ²⁾	10	1429430000

*¹⁾ 1 roll = 1000 label = 1 Qty.
*²⁾ 1 sheet = 60 label = 1 Qty.

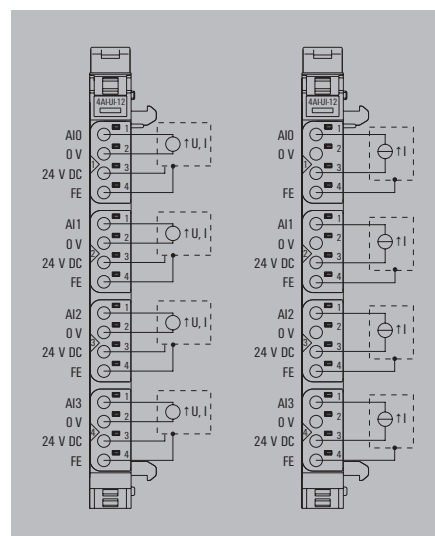

Product standard	IEC 61131-2
EMC	EN 61000
ATEX	EN 60079
UL (in preparation)	UL 508



Let's connect.

8AI-PLC-INT

- 8 analogue inputs
- Rapid cabling with flat ribbon cable
- 0/4 to 20 mA with 0.1 % accuracy with a 16-bit resolution
- Inputs can be parameterised (passive or active operating mode)

UR20-8AI-PLC-INT



Technical data

System data	
Interface	u-remote system bus
Transmission rate of system bus	48 Mbit/s
Galvanic isolation	yes, DC 500 V between current paths
Supply	
Voltage supply	24 V DC +20 % / - 15 % via the system bus
Current consumption (I _N in power segment of field bus coupler), typ.	8 mA
Current consumption (I _N external)	20 mA
Analogue inputs	
Number	8
Input	Current input
Resolution	16 Bit
Accuracy	0.1 % FSR
Sensor supply	external
Sensor connection	PLC interface
Conversion time	1 ms
Internal resistance I	approx. 50 Ω
Reverse polarity protection	yes
Module diagnosis	yes
Individual channel diagnosis	no
Short-circuit-proof	yes
General data	
Weight	73 g
Dimensions (H/W/D)	120 mm (with catch lever) 128 mm x 11,5 mm x 76 mm

System data		
Interface	u-remote system bus	
Transmission rate of system bus	48 Mbit/s	
Galvanic isolation	yes, DC 500 V between current paths	
Supply		
Voltage supply	24 V DC +20 % / - 15 % via the system bus	
Current consumption (I _N in power segment of field bus coupler), typ.	8 mA	
Current consumption (I _N external)	20 mA	
Analogue inputs		
Number	8	
Input	Current input	
Resolution	16 Bit	
Accuracy	0.1 % FSR	
Sensor supply	external	
Sensor connection	PLC interface	
Conversion time	1 ms	
Internal resistance I	approx. 50 Ω	
Reverse polarity protection	yes	
Module diagnosis	yes	
Individual channel diagnosis	no	
Short-circuit-proof	yes	
General data		
Weight	73 g	
Dimensions (H/W/D)	120 mm (with catch lever) 128 mm x 11,5 mm x 76 mm	

Ordering data

Module variants	
Analogue input module, 8 channels, PLC interface	

Type	Qty.	Order No.
UR20-8AI-PLC-INT	1	1315670000

Accessories

Accessories	
Coding elements	
Termination kit	
Swivel marker	
Connection marker for pusher custom printing	
Connection marker for pusher neutral	
Module marker for custom printing	
Module marker for neutral	
Thermotransfer version (Material: Polyester)	
Thermotransfer version (Material: Polyester)	
Paper version for Laserprinter	
Replacement parts	
Electronics module	
Basic module	
Plug-in connector unit	
PLC interface element	
Pre-assembled cable, 1m	
Note	

Type	Qty.	Order No.
KDSM BHZ5.00	100	1483050000
UR20-EBK-ACC	5	1346610000
UR20-SM-ACC	20	1339920000
PM 2.7/2.6 MC SDR	192	1323700000
PM 2.7/2.6 MC NE WS	960	1323710000
DEK 5/8-11.5 MC SDR	100	1341610000
DEK 5/8-11.5 MC NE WS	500	1341630000
THM UR20 GE * ¹⁾	1	1429910000
THM UR20 WS * ¹⁾	1	1429420000
ESO UR20 DIN A4 WS * ²⁾	10	1429430000
UR20-EM-1315670000-SP	1	1347250000
UR20-BM-SP	5	1350930000
UR20-PK-1315670000-SP	5	1483950000
RS 16IO 1W H S	1	9445700000
PAC-UNIV-HE20-LCH-1M	1	7789306010

*¹⁾ 1 roll = 1000 label = 1 Qty.
*²⁾ 1 sheet = 60 label = 1 Qty.

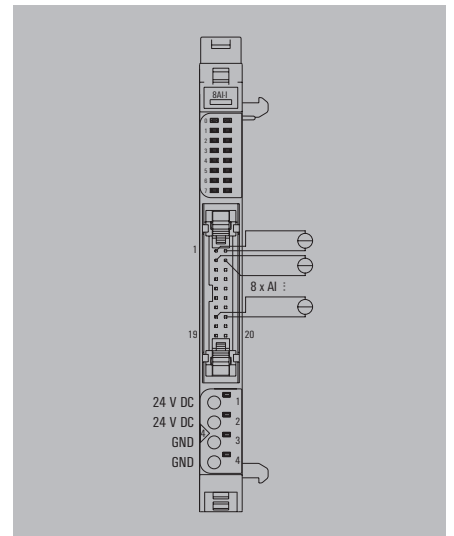

Product standard	IEC 61131-2
EMC	EN 61000
ATEX	EN 60079
UL	UL 508



Let's connect.

Temperature modules

Available for TC and RTD; 16-bit resolution;
50/60 Hz suppression

IP 20
A

The recording of resistance temperature and thermocoupler sensors is indispensable for many applications. The 4-channel input modules from Weidmüller are designed for all common thermal elements and resistance temperature sensors. With an accuracy of 0.2 % of the measurement range end value and a resolution of 16 bits, cable breaks and instances of the limit value being exceeded or falling below are detected by means of individual channel diagnosis. Additional features such as an automatic 50-Hz to 60-Hz suppression or external as well as internal cold-junction compensation, as are available with the TC module, round off the scope of function.

The module electronics supply the connected sensors from the input current path (U_{IN}).

UR20-4AI-TC-DIAG block diagram example

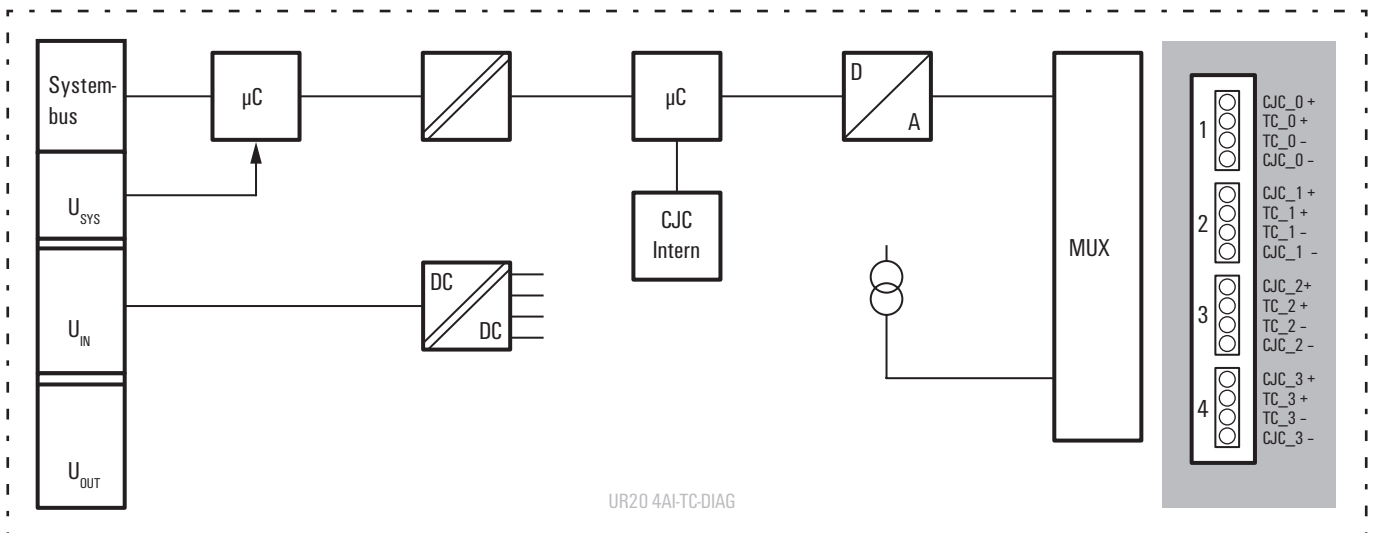

4AI-TC-DIAG

- 4 analogue inputs
- Various TC sensors
- High accuracy of 0.2 % FSR
- 16-bit resolution
- Individual channel diagnosis
- Internal or external cold-junction compensation possible
- Automatic 50 and 60 Hz suppression

UR20-4AI-TC-DIAG



Technical data

System data	
Interface	u-remote system bus
Transmission rate of system bus	48 Mbit/s
Galvanic isolation	yes, DC 500 V between current paths
Supply	
Voltage supply	24 V DC +20 % / -15 % via the system bus
Current consumption (I _N in power segment of field bus coupler), typ.	8 mA
Current consumption (I _N in the respective power segment)	20 mA
Analogue inputs	
Number	4
Sensor type	J, K, T, B, N, E, R, S, L, U, C, mV
Resolution	16 Bit
Accuracy	0,1 % FSR + 10 µV
Sensor connection	2-wire
Cold-junction compensation	internal and external (int. accuracy ≤ 3 K)
Temperature coefficient	50 ppm/K
Temperature range	-200...+2315 °C
Conversion time	36...240 ms, adjustable
Internal resistance	> 1 MΩ
Module diagnosis	yes
Individual channel diagnosis	yes
Reverse polarity protection	yes
General data	
Weight	86 g
Dimensions (H/W/D)	120 mm (with catch lever 128 mm) x 11,5 mm x 76 mm

Ordering data

Module variants	
Analogue input module, 4 channels, thermocouple	

Type	Qty.	Order No.
UR20-4AI-TC-DIAG	1	1315710000

Accessories

Accessories	
Coding elements	
Termination kit	
Swivel marker	
Connection marker for pusher custom printing	
Connection marker for pusher neutral	
Module marker for custom printing	
Module marker for neutral	
Thermotransfer version (Material: Polyester)	
Thermotransfer version (Material: Polyester)	
Paper version for Laserprinter	
Replacement parts	
Electronics module	
Basic module	
Plug-in connector unit	
Note	

Type	Qty.	Order No.
KOSM BHZ5.00	100	1483050000
UR20-EBK-ACC	5	1346610000
UR20-SM-ACC	20	1339920000
PM 2.7/2.6 MC SDR	192	1323700000
PM 2.7/2.6 MC NE WS	960	1323710000
DEK 5/8-11.5 MC SDR	100	1341610000
DEK 5/8-11.5 MC NE WS	500	1341630000
THM UR20 GE * ¹⁾	1	1429910000
THM UR20 WS * ¹⁾	1	1429420000
ESD UR20 DIN A4 WS * ²⁾	10	1429430000
UR20-EM-1315710000-SP	1	1435740000
UR20-BM-SP	5	1350930000
UR20-PK-1315710000-SP	5	1484050000

*¹⁾ 1 roll = 1000 label = 1 Qty.
*²⁾ 1 sheet = 60 label = 1 Qty.

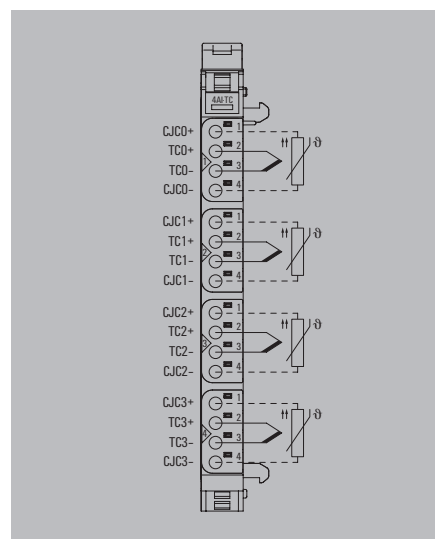

Product standard	IEC 61131-2
EMC	EN 61000
ATEX	EN 60079
UL	UL 508



Let's connect.

4AI-RTD-DIAG

- 16-bit resolution
- Individual channel diagnosis
- Automatic 50 and 60 Hz suppression
- For 2-, 3- and 4-wire RTDs
- High accuracy
- For virtually all common sensors
- Temperature measurement via resistor

UR20-4AI-RTD-DIAG



Technical data

System data	
Interface	u-remote system bus
Transmission rate of system bus	48 Mbit/s
Galvanic isolation	yes, DC 500 V between current paths
Supply	
Voltage supply	24 V DC +20 % / -15 % via the system bus
Current consumption (I _N in power segment of field bus coupler), typ.	8 mA
Current consumption (I _N in the respective power segment)	20 mA
Analogue inputs	
Number	4
Sensor type	Pt100, Pt200, Pt500, Pt1000, Ni100, Ni120, Ni200, Ni500, Ni1000, Cu10, resistors with 40 Ω, 80 Ω, 150 Ω, 300 Ω, 500 Ω, 1 kΩ, 2 kΩ, 4 kΩ
Resolution	16 Bit
Accuracy	0.2 % FSR, 0.3 % FSR for Ni sensors, 0.6 % FSR for Cu10
Sensor connection	2-wire, 3-wire, 4-wire
Temperature coefficient	50 ppm/K
Temperature range	-200...+850 °C
Conversion time	36...240 ms adjustable
Internal resistance	> 1 MΩ
Reverse polarity protection	yes
Module diagnosis	yes
Individual channel diagnosis	yes
General data	
Weight	91 g
Dimensions (H/W/D)	120 mm (with catch lever) 128 mm x 11,5 mm x 76 mm

Ordering data

Module variants	
Analogue input module, 4 channels, RTD	

Type	Qty.	Order No.
UR20-4AI-RTD-DIAG	1	1315700000

Accessories

Replacement parts	
Electronics module	UR20-EM-1315700000-SP
Basic module	UR20-BM-SP
Plug-in connector unit	UR20-PK-1315700000-SP
Note	

Type	Qty.	Order No.
KDSM BHZ5.00	100	1483050000
UR20-EBK-ACC	5	1346610000
UR20-SM-ACC	20	1339920000
PM 2.7/2.6 MC SDR	192	1323700000
PM 2.7/2.6 MC NE WS	960	1323710000
DEK 5/8-11.5 MC SDR	100	1341610000
DEK 5/8-11.5 MC NE WS	500	1341630000
THM UR20 GE * ¹⁾	1	1429910000
THM UR20 WS * ¹⁾	1	1429420000
ESO UR20 DIN A4 WS * ²⁾	10	1429430000
* ¹⁾ 1 roll = 1000 label = 1 Qty.		
* ²⁾ 1 sheet = 60 label = 1 Qty.		

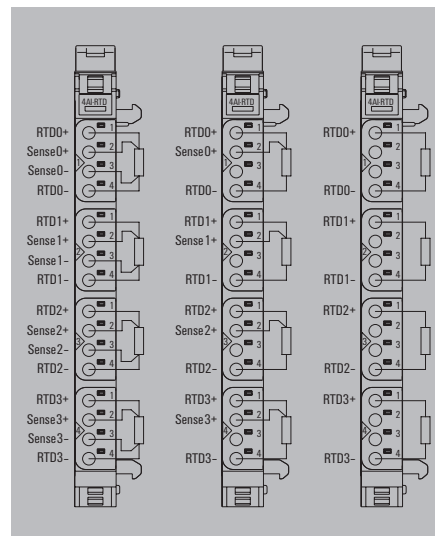

Product standard	
EMC	IEC 61131-2
ATEX	EN 61000
UL	EN 60079
	UL 508



Let's connect.

Analogue output module

2- or 4-wire connection; 16-bit resolution; 4 outputs

IP 20
A

The analogue output module controls up to 4 analogue actuators with +/-10 V, +/-5 V, 0...10 V, 0...5 V, 2...10 V, 1...5 V, 0...20 mA or 4...20 mA with an accuracy of 0.05 % of the measurement range end value. An actuator with 2- or 4-wire technology can be connected to each plug-in connector. The outputs are defined channel by channel using parameterisation. A separate status LED is assigned to each channel.

The outputs are supplied from the output current path (U_{OUT}).

Block diagram UR20-4AO-UI-16

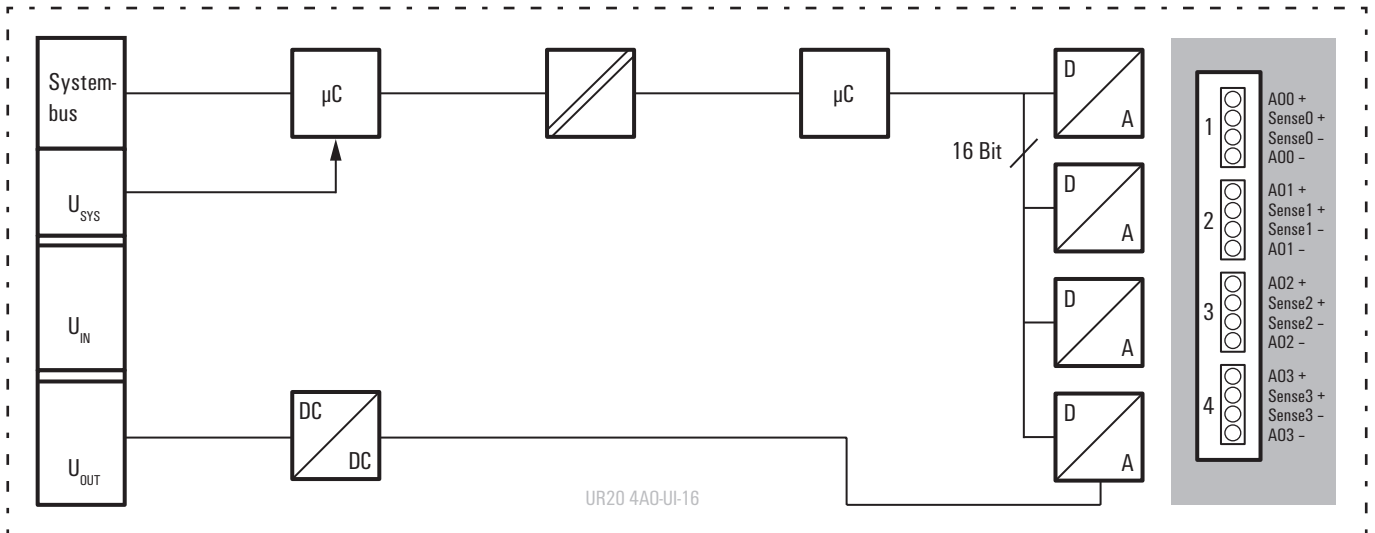

4AO-UI-16

- 4 analogue outputs
- Outputs can be parameterised by channel (voltage, current)
- 16-bit resolution
- 2- and 4-wire connection
- Accuracy typ. 0.05 % FSR
- Replacement values can be set per channel
- Non reactiv
- Short-circuit-proof

UR20-4AO-UI-16



Technical data

System data	
Interface	u-remote system bus
Transmission rate of system bus	48 Mbit/s
Galvanic isolation	yes, DC 500 V between current paths
Supply	
Voltage supply	24 V DC +20 % / - 15 % via the system bus
Current consumption (I _{IN} in power segment of field bus coupler), typ.	8 mA
Current consumption (I _{OUT} in the respective power segment)	85 mA
Analogue outputs	
Number	4
Output	1. Voltage (0...5 V, 0...10 V, 1...5 V, 2...10 V, ±5 V) 2. Current (0...20 mA or 4...20 mA)
Response time	1 ms for 4 channels
Resolution	16 Bit
Accuracy	±0.1 % FSR max., 0.05 % FSR typ.
Load resistance, voltage output	> 1 kΩ (at > 50 °C ambient temperature max. sum of sensor current = 25 mA)
Load resistance, current output	< 600 Ω
Actuator connection	2-wire (current and voltage), 3- and 4-wire (voltage), (2-wire: automatic detection)
Temperature coefficient	20 ppm Voltage / 31 ppm current measurement / °K
Max. error between T min. and T max.	220 ppm FSR
Monotonicity	yes
Crosstalk between the channels	0,001 % FSR
Repeat accuracy	< 1 mV effectively
Output waviness	max. 0.001 %
Module diagnosis	yes
Replacement values	yes
General data	
Weight	83 g
Dimensions (H/W/D)	120 mm (with catch lever 128 mm) x 11,5 mm x 76 mm

Ordering data

Module variants	
Analogue output module, 4 channels, 16 Bit	

Type	Qty.	Order No.
UR20-4AO-UI-16	1	1315680000

Accessories

Accessories	
Coding elements	
Termination kit	
Swivel marker	
Connection marker for pusher custom printing	
Connection marker for pusher neutral	
Module marker for custom printing	
Module marker for neutral	
Thermotransfer version (Material: Polyester)	
Thermotransfer version (Material: Polyester)	
Paper version for Laserprinter	
Replacement parts	
Electronics module	
Basic module	
Plug-in connector unit	
Note	

Type	Qty.	Order No.
KOSM BHZ5 00	100	1483050000
UR20-EBK-ACC	5	1346610000
UR20-SM-ACC	20	1339920000
PM 2.7/2.6 MC SDR	192	1323700000
PM 2.7/2.6 MC NE WS	960	1323710000
DEK 5/8-11.5 MC SDR	100	1341610000
DEK 5/8-11.5 MC NE WS	500	1341630000
THM UR20 GE * ¹⁾	1	1429910000
THM UR20 WS * ¹⁾	1	1429420000
ESD UR20 DIN A4 WS * ²⁾	10	1429430000
UR20-EM-1315680000-SP	1	1347270000
UR20-BM-SP	5	1350930000
UR20-PK-1315680000-SP	5	1484070000

*¹⁾ 1 roll = 1000 label = 1 Qty.
*²⁾ 1 sheet = 60 label = 1 Qty.

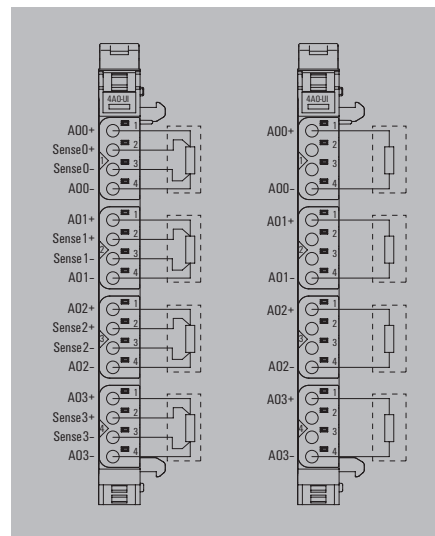

Product standard	IEC 61131-2
EMC	EN 61000
ATEX	EN 60079
UL	UL 508



Let's connect.

4AO-UI-16-DIAG

- Advanced diagnosis functions
- 4 analogue outputs
- Outputs can be parameterised by channel (voltage, current)
- 16-bit resolution
- 2- and 4-wire connection
- Accuracy typ. 0.05 % FSR
- Replacement values can be set per channel
- Non reactive
- Short-circuit-proof

UR20-4AO-UI-16-DIAG



Technical data

System data	
Interface	u-remote system bus
Transmission rate of system bus	48 Mbit/s
Galvanic isolation	yes, DC 500 V between current paths
Supply	
Voltage supply	24 V DC +20 % / - 15 % via the system bus
Current consumption (I _{in} in power segment of field bus coupler), typ.	8 mA
Current consumption (I _{out} in the respective power segment)	85 mA
Analogue outputs	
Number	4
Output	1. Voltage (0...5 V, 0...10 V, 1...5 V, 2...10 V, ±5 V) 2. Current (0...20 mA or 4...20 mA)
Response time	1 ms for 4 channels
Resolution	16 Bit
Accuracy	±0.1 % FSR max., 0.05 % FSR typ.
Load resistance, voltage output	> 1 kΩ (at > 50 °C ambient temperature max. sum of sensor current = 25 mA)
Load resistance, current output	< 600 Ω
Actuator connection	2-wire (current and voltage), 3- and 4-wire (voltage), (2-wire: automatic detection)
Temperature coefficient	20 ppm Voltage / 31 ppm current measurement / °K
Max. error between T min. and T max.	220 ppm FSR
Monotonicity	yes
Crosstalk between the channels	0,001 % FSR
Repeat accuracy	< 1 mV effectively
Output waviness	max. 0.001 %
Module diagnosis	yes
Einzelkanaldiagnose	yes
Replacement values	yes
General data	
Weight	98 g
Dimensions (H/W/D)	120 mm (with catch lever 128 mm) x 11,5 mm x 76 mm

Ordering data

Module variants	
Analogue output module, 4 channels, 16 Bits, diagnosis functions	

Type	Qty.	Order No.
UR20-4AO-UI-16-DIAG	1	1315730000

Accessories

Accessories	
Coding elements	KDSM BHZ5.00
Termination kit	UR20-EBK-ACC
Swivel marker	UR20-SM-ACC
Connection marker for pusher custom printing	PM 2.7/2.6 MC SDR
Connection marker for pusher neutral	PM 2.7/2.6 MC NE WS
Module marker for custom printing	DEK 5/8-11.5 MC SDR
Module marker for neutral	DEK 5/8-11.5 MC NE WS
Thermotransfer version (Material: Polyester)	THM UR20 GE * ¹⁾
Thermotransfer version (Material: Polyester)	THM UR20 WS * ¹⁾
Paper version for Laserprinter	ESO UR20 DIN A4 WS * ²⁾
Replacement parts	
Electronics module	UR20-EM-1315730000-SP
Basic module	UR20-BM-1315730000-SP
Plug-in connector unit	UR20-PK-1315730000-SP
Note	

Type	Qty.	Order No.
KDSM BHZ5.00	100	1483050000
UR20-EBK-ACC	5	1346610000
UR20-SM-ACC	20	1339920000
PM 2.7/2.6 MC SDR	192	1323700000
PM 2.7/2.6 MC NE WS	960	1323710000
DEK 5/8-11.5 MC SDR	100	1341610000
DEK 5/8-11.5 MC NE WS	500	1341630000
THM UR20 GE * ¹⁾	1	1429910000
THM UR20 WS * ¹⁾	1	1429420000
ESO UR20 DIN A4 WS * ²⁾	10	1429430000
UR20-EM-1315730000-SP	1	1347330000
UR20-BM-1315730000-SP	5	1350930000
UR20-PK-1315730000-SP	5	1518880000

*¹⁾ 1 roll = 1000 label = 1 Qty.
*²⁾ 1 sheet = 60 label = 1 Qty.

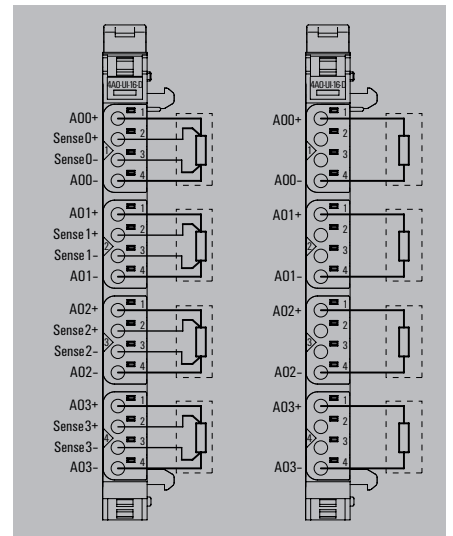

Product standard	IEC 61131-2
EMC	EN 61000
ATEX	EN 60079
UL (in preparation)	UL 508



Let's connect.

Power-feed modules

10 A feeding; input or output current path; diagnosis visualisation

IP 20
A

Weidmüller power-feed modules are available to refresh the power of the input and output current path. These feed 10 A, monitored by the voltage diagnosis display, in the corresponding input or output path. The time-saving commissioning is guaranteed by the standard u-remote plug with proven and tested "PUSH IN" technology for reliable contacting. The power supply is monitored by a diagnosis display.

Block diagram UR20-PF-I and UR20-PF-O

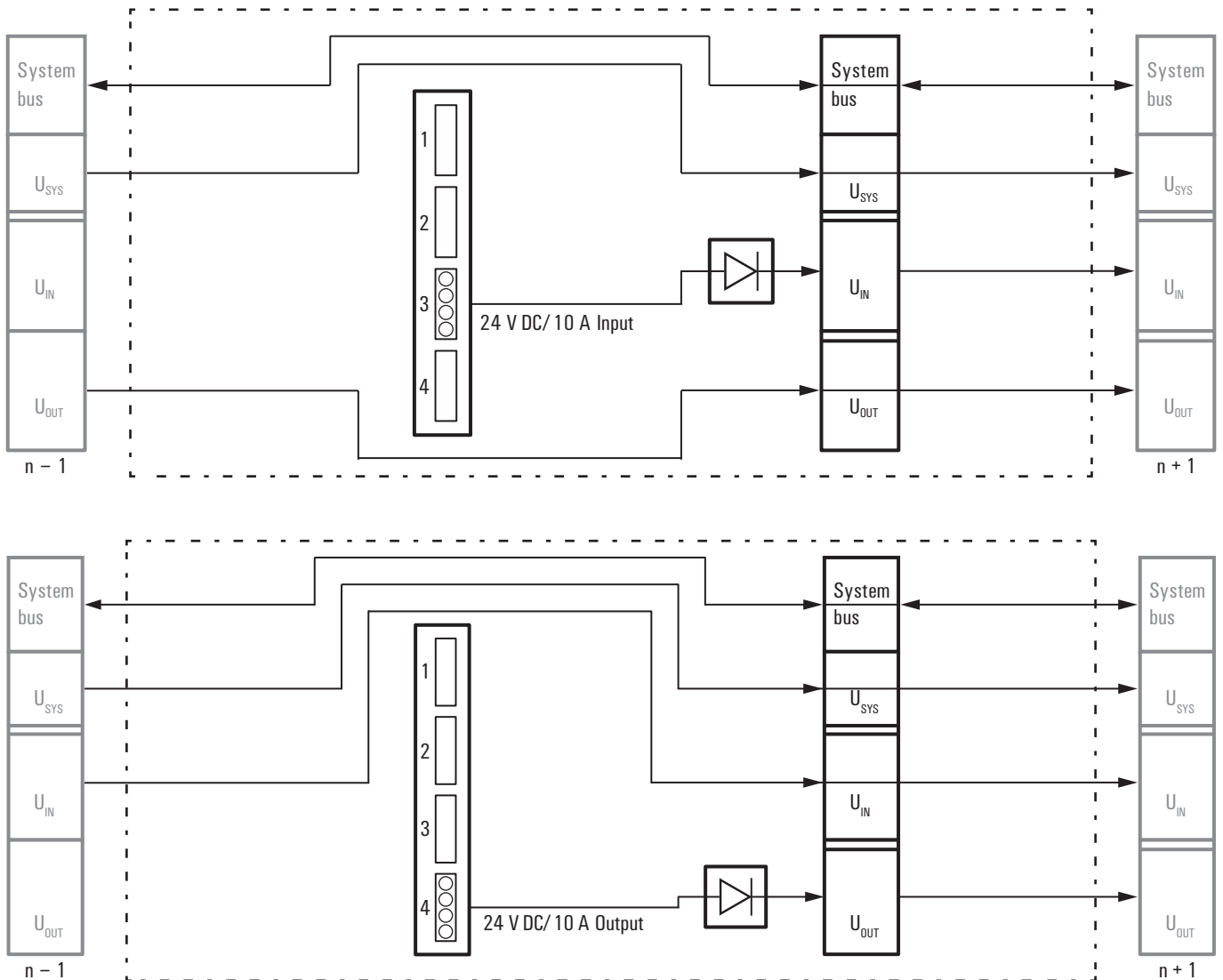

PF-I

- Power supply in input current path
- Power supply current 10 A
- Integrated diagnosis display

UR20-PF-I



Technical data

Supply	
Voltage supply for inputs	24 V DC +20 % / - 15 %
Maximum feed current for input modules	10 A
Current consumption (I _N in the respective power segment)	10 mA
General data	
Weight	76 g
Dimensions (H/W/D)	120 mm (with catch lever 128 mm) x 11,5 mm x 76 mm

Ordering data

Module variants	
Power supply module	

Type	Qty.	Order No.
UR20-PF-I	1	1334710000

Accessories

Coding elements	
Termination kit	
Swivel marker	
Connection marker for pusher custom printing	
Connection marker for pusher neutral	
Module marker for custom printing	
Module marker for neutral	
Thermotransfer version (Material: Polyester)	
Thermotransfer version (Material: Polyester)	
Paper version for Laserprinter	

Type	Qty.	Order No.
KOSM BHZ5.00	100	1483050000
UR20-EBK-ACC	5	1346610000
UR20-SM-ACC	20	1339920000
PM 2.7/2.6 MC SDR	192	1323700000
PM 2.7/2.6 MC NE WS	960	1323710000
DEK 5/8-11.5 MC SDR	100	1341610000
DEK 5/8-11.5 MC NE WS	500	1341630000
THM UR20 GE * ¹⁾	1	1429910000
THM UR20 WS * ¹⁾	1	1429420000
ESD UR20 DIN A4 WS * ²⁾	10	1429430000

Replacement parts	
Electronics module	UR20-EM-1334710000-SP 1 1347380000
Basic module	UR20-BM-PF-I-SP 5 1350940000
Plug-in connector unit	UR20-PK-1334710000-SP 5 1346460000
Note	

*¹⁾ 1 roll = 1000 label = 1 Qty.
 *²⁾ 1 sheet = 60 label = 1 Qty.

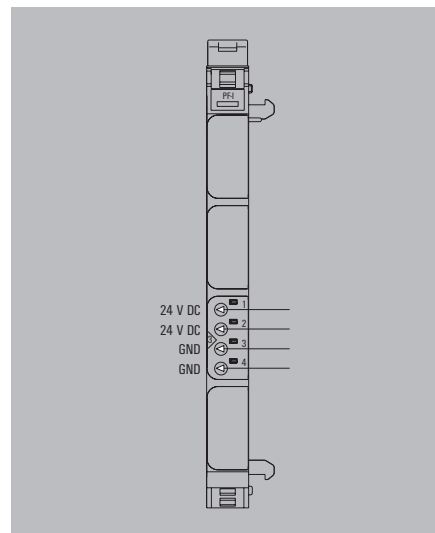

Product standard	IEC 61131-2
EMC	EN 61000
ATEX	EN 60079
UL	UL 508



Let's connect.

PF-0

- Power supply in output current path
- Power supply current 10 A
- Integrated diagnosis display

UR20-PF-0



Technical data

Supply	
Voltage supply for outputs	24 V DC +20 % / - 15 %
Maximum feed current for output modules	10 A
Current consumption (I_{OUT} in the respective power segment)	10 mA
General data	
Weight	76 g
Dimensions (H/W/D)	120 mm (with catch lever 128 mm) x 11,5 mm x 76 mm

Ordering data

Module variants	
Power supply module	

Type	Qty.	Order No.
UR20-PF-0	1	1334740000

Accessories

Coding elements	
Termination kit	
Swivel marker	
Connection marker for pusher custom printing	
Connection marker for pusher neutral	
Module marker for custom printing	
Module marker for neutral	
Thermotransfer version (Material: Polyester)	
Thermotransfer version (Material: Polyester)	
Paper version for Laserprinter	

Type	Qty.	Order No.
KOSM BHZ5.00	100	1483050000
UR20-EBK-ACC	5	1346610000
UR20-SM-ACC	20	1339920000
PM 2.7/2.6 MC SDR	192	1323700000
PM 2.7/2.6 MC NE WS	960	1323710000
DEK 5/8-11.5 MC SDR	100	1341610000
DEK 5/8-11.5 MC NE WS	500	1341630000
THM UR20 GE * ¹⁾	1	1429910000
THM UR20 WS * ¹⁾	1	1429420000
ESD UR20 DIN A4 WS * ²⁾	10	1429430000

Replacement parts	
Electronics module	UR20-EM-1334740000-SP 1 1347420000
Basic module	UR20-BM-PF-0-SP 5 1350950000
Plug-in connector unit	UR20-PK-1334740000-SP 5 1346480000
Note	

*¹⁾ 1 roll = 1000 label = 1 Qty.
*²⁾ 1 sheet = 60 label = 1 Qty.

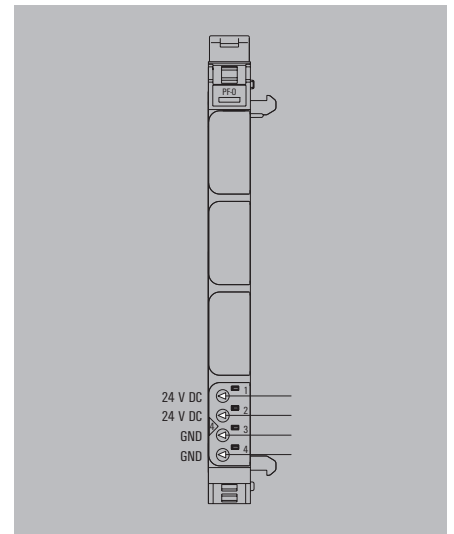

Product standard	IEC 61131-2
EMC	EN 61000
ATEX	EN 60079
UL	UL 508



Let's connect.

Modules for functional safety

SIL 3; OSSD output; wire breakage and short-circuit detection

IP 20
A

Safety technology is of central importance in the automation industry and machine construction. When attempting to reduce risks and avoid putting people and the environment in danger, you need solutions which satisfy stringent requirements and statutory specifications. The safety modules of the u-remote system have key features such as emergency stop circuits and wire breakage/short-circuit detection. They satisfy all SIL 3 requirements according to IEC 62061 and EN ISO 13849-1, Category 4, PL e and support the safe operation of your system.

By safely shutting down the downstream output modules, the safety modules attain maximum safety with optimum control. All input sensors are independently supplied via separate voltage paths and report the current machine status to the control unit. The restart is either performed in manual mode or using the autostart function.

Safety modules from Weidmüller also cut maintenance and service times and improve your response times in an emergency – thanks to a concept of maximum transparency, e.g. using OSSD output.

The module electronics supply the connected actuators from the output current path (U_{OUT}).

UR20-PF-O-1DI-SIL block diagram example

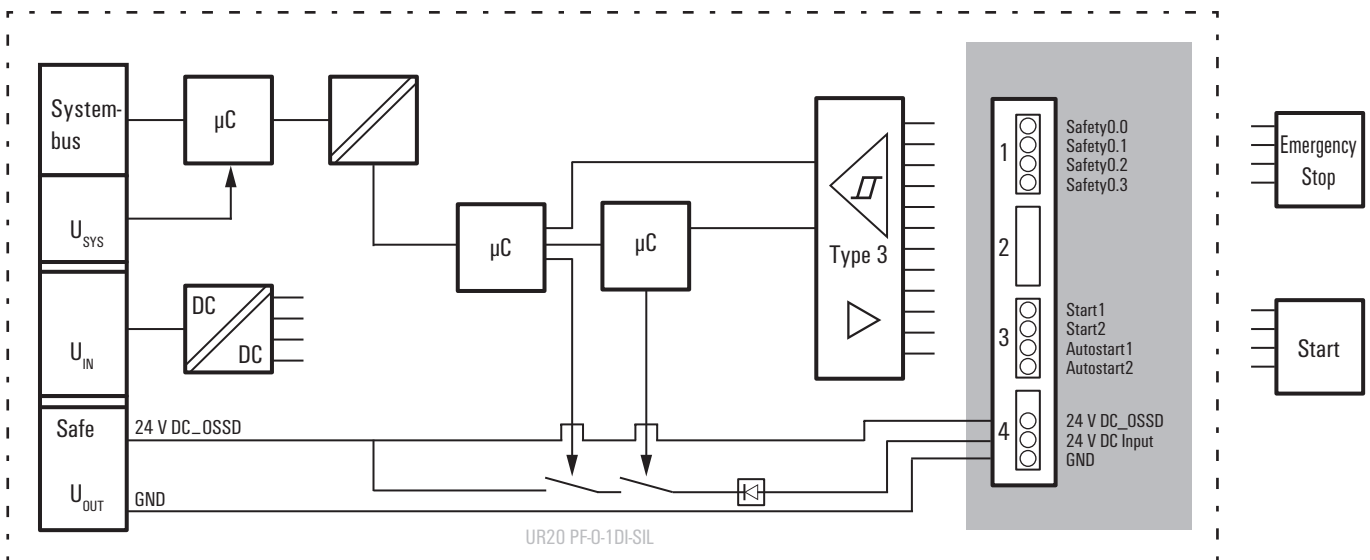

PF-0-1DI-SIL

- SIL 3 safety standard in accordance with IEC 62061 and DIN EN ISO 13849-1, category 4, PL e
- Connection for an emergency stop circuit
- OSSD output reports status to control unit
- Pulsed input circuit for wire breakage and short-circuit detection
- Restart: manual or using autostart

UR20-PF-0-1DI-SIL



Technical data

System data	
Interface	u-remote system bus
Transmission rate of system bus	48 Mbit/s
Safety-related data	
Achievable safety standard	IEC 61508 SIL 3 and DIN EN ISO 13849-1:2008 PL e
Level of diagnostic coverage	*)
MTTFD	*)
CCF	*)
Supply	
Supply voltage for system and inputs	24 V DC +20 % / -15 % via the system bus
Supply voltage for outputs	24 V DC +20 % / -15 %
Maximum feed current for input modules	8 A
Current consumption (internal)	< 45 mA
Digital inputs	
Wire breakage detection	yes
Short-circuit detection	yes
General data	
Weight	80 g
Dimensions (H/W/D)	120 mm (with catch lever 128 mm) x 11,5 mm x 76 mm

System data		
Interface	u-remote system bus	
Transmission rate of system bus	48 Mbit/s	
Safety-related data		
Achievable safety standard	IEC 61508 SIL 3 and DIN EN ISO 13849-1:2008 PL e	
Level of diagnostic coverage	*)	
MTTFD	*)	
CCF	*)	
Supply		
Supply voltage for system and inputs	24 V DC +20 % / -15 % via the system bus	
Supply voltage for outputs	24 V DC +20 % / -15 %	
Maximum feed current for input modules	8 A	
Current consumption (internal)	< 45 mA	
Digital inputs		
Wire breakage detection	yes	
Short-circuit detection	yes	
General data		
Weight	80 g	
Dimensions (H/W/D)	120 mm (with catch lever 128 mm) x 11,5 mm x 76 mm	

Ordering data

Module variants	
Safety module, 1 digital input	

Type	Qty.	Order No.
UR20-PF-0-1DI-SIL	1	1335030000

*) For this and additional technical data, please refer to the manual available at www.weidmueller.de or scan the QR code below.

Accessories

Accessories	
Coding elements	
Termination kit	
Swivel marker	
Connection marker for pusher custom printing	
Connection marker for pusher neutral	
Module marker for custom printing	
Module marker for neutral	
Thermotransfer version (Material: Polyester)	
Thermotransfer version (Material: Polyester)	
Paper version for Laserprinter	
Replacement parts	
Electronics module	
Basic module	
Plug-in connector unit	
Note	

Type	Qty.	Order No.
KOSM BHZ5.00	100	1483050000
UR20-EBK-ACC	5	1346610000
UR20-SM-ACC	20	1339920000
PM 2.7/2.6 MC SDR	192	1323700000
PM 2.7/2.6 MC NE WS	960	1323710000
DEK 5/8-11.5 MC SDR	100	1341610000
DEK 5/8-11.5 MC NE WS	500	1341630000
THM UR20 GE *)	1	1429910000
THM UR20 WS *)	1	1429420000
ESD UR20 DIN A4 WS *)	10	1429430000
Replacement parts		
UR20-EM-1335030000-SP	1	1347520000
UR20-BM-SIL-SP	5	1350970000
UR20-PK-1335030000-SP	5	1346560000

*)1 roll = 1000 label = 1 Qty.
*)2 1 sheet = 60 label = 1 Qty.

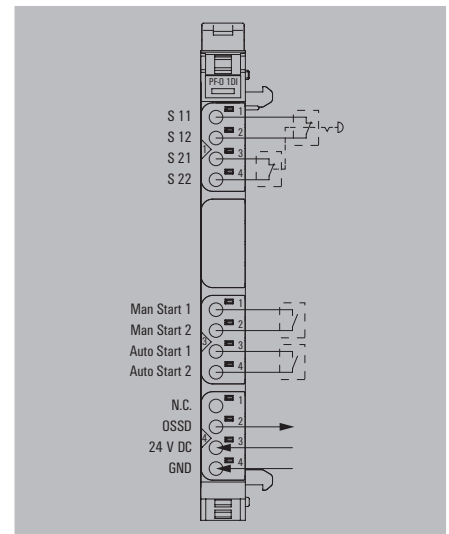

Product standard	IEC 61131-2
EMC	EN 61000
ATEX	EN 60079
UL (in preparation)	UL 508



Let's connect.

PF-0-2DI-SIL

- SIL 3 safety standard in accordance with IEC 62061 and DIN EN ISO 13849-1, category 4, PL e
- Connection for an emergency stop circuit
- OSSD output reports status to control unit
- Pulsed input circuit for wire breakage and short-circuit detection
- Restart: manual or using autostart

UR20-PF-0-2DI-SIL



Technical data

System data	
Interface	u-remote system bus
Transmission rate of system bus	48 Mbit/s
Safety-related data	
Achievable safety standard	IEC 61508 SIL 3 and DIN EN ISO 13849-1:2008 PL e
Level of diagnostic coverage	*)
MTTFD	*)
CCF	*)
Supply	
Supply voltage for system and inputs	24 V DC +20 % / -15 % via the system bus
Supply voltage for outputs	24 V DC +20 % / -15 %
Maximum feed current for input modules	8 A
Current consumption (internal)	< 45 mA
Digital inputs	
Wire breakage detection	yes
Short-circuit detection	yes
General data	
Weight	82 g
Dimensions (H/W/D)	120 mm (with catch lever 128 mm) x 11,5 mm x 76 mm

System data		
Interface	u-remote system bus	
Transmission rate of system bus	48 Mbit/s	
Safety-related data		
Achievable safety standard	IEC 61508 SIL 3 and DIN EN ISO 13849-1:2008 PL e	
Level of diagnostic coverage	*)	
MTTFD	*)	
CCF	*)	
Supply		
Supply voltage for system and inputs	24 V DC +20 % / -15 % via the system bus	
Supply voltage for outputs	24 V DC +20 % / -15 %	
Maximum feed current for input modules	8 A	
Current consumption (internal)	< 45 mA	
Digital inputs		
Wire breakage detection	yes	
Short-circuit detection	yes	
General data		
Weight	82 g	
Dimensions (H/W/D)	120 mm (with catch lever 128 mm) x 11,5 mm x 76 mm	

Ordering data

Module variants	
Safety module, 2 digital inputs	

Type	Qty.	Order No.
UR20-PF-0-2DI-SIL	1	1335050000

*) For this and additional technical data, please refer to the manual available at www.weidmueller.de or scan the QR code below.

Accessories

Coding elements	
Termination kit	
Swivel marker	
Connection marker for pusher custom printing	
Connection marker for pusher neutral	
Module marker for custom printing	
Module marker for neutral	
Thermotransfer version (Material: Polyester)	
Thermotransfer version (Material: Polyester)	
Paper version for Laserprinter	
Replacement parts	
Electronics module	
Basic module	
Plug-in connector unit	
Note	

Type	Qty.	Order No.
KOSM BHZ5.00	100	1483050000
UR20-EBK-ACC	5	1346610000
UR20-SM-ACC	20	1339920000
PM 2.7/2.6 MC SDR	192	1323700000
PM 2.7/2.6 MC NE WS	960	1323710000
DEK 5/8-11.5 MC SDR	100	1341610000
DEK 5/8-11.5 MC NE WS	500	1341630000
THM UR20 GE *)	1	1429910000
THM UR20 WS *)	1	1429420000
ESD UR20 DIN A4 WS *)	10	1429430000
Replacement parts		
UR20-EM-1335050000-SP	1	1347540000
UR20-BM-SIL-SP	5	1350970000
UR20-PK-1335050000-SP	5	1346570000

*)1 1 roll = 1000 label = 1 Qty.
 *)2 1 sheet = 60 label = 1 Qty.

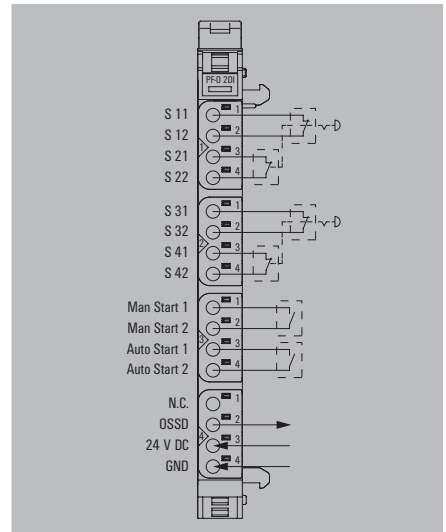

Product standard	IEC 61131-2
EMC	EN 61000
ATEX	EN 60079
UL (in preparation)	UL 508



Let's connect.

PF-O-2DI-DELAY-SIL

- SIL 3 safety standard in accordance with IEC 62061 and DIN EN ISO 13849-1, category 4, PL e
- Switch-off after adjustable delay
- Connection for an emergency stop circuit
- OSSD output reports status to control unit
- Pulsed input circuit for wire breakage and short-circuit detection
- Restart: manual or using autostart

UR20-PF-O-2DI-DELAY-SIL



Technical data

System data	
Interface	u-remote system bus
Transmission rate of system bus	48 Mbit/s
Safety-related data	
Achievable safety standard	IEC 61508 SIL 3 and DIN EN ISO 13849-1:2008 PL e
Level of diagnostic coverage	*)
MTTFD	*)
CCF	*)
Supply	
Supply voltage for system and inputs	24 V DC +20 % / - 15 % via the system bus
Supply voltage for outputs	24 V DC +20 % / - 15 %
Maximum feed current for input modules	8 A
Current consumption (internal)	< 45 mA
Digital inputs	
Wire breakage detection	yes
Short-circuit detection	yes
General data	
Weight	84 g
Dimensions (H/W/D)	120 mm (with catch lever 128 mm) x 11,5 mm x 76 mm

System data		
Interface	u-remote system bus	
Transmission rate of system bus	48 Mbit/s	
Safety-related data		
Achievable safety standard	IEC 61508 SIL 3 and DIN EN ISO 13849-1:2008 PL e	
Level of diagnostic coverage	*)	
MTTFD	*)	
CCF	*)	
Supply		
Supply voltage for system and inputs	24 V DC +20 % / - 15 % via the system bus	
Supply voltage for outputs	24 V DC +20 % / - 15 %	
Maximum feed current for input modules	8 A	
Current consumption (internal)	< 45 mA	
Digital inputs		
Wire breakage detection	yes	
Short-circuit detection	yes	
General data		
Weight	84 g	
Dimensions (H/W/D)	120 mm (with catch lever 128 mm) x 11,5 mm x 76 mm	

Ordering data

Module variants	
Safety module, 2 digital inputs, delayed	

Type	Qty.	Order No.
UR20-PF-O-2DI-DELAY-SIL	1	1335040000

*) For this and additional technical data, please refer to the manual available at www.weidmueller.de or scan the QR code below.

Accessories

Coding elements	
Termination kit	
Swivel marker	
Connection marker for pusher custom printing	
Connection marker for pusher neutral	
Module marker for custom printing	
Module marker for neutral	
Thermotransfer version (Material: Polyester)	
Thermotransfer version (Material: Polyester)	
Paper version for Laserprinter	
Replacement parts	
Electronics module	
Basic module	
Plug-in connector unit	
Note	

Type	Qty.	Order No.
KOSM BHZ5.00	100	1483050000
UR20-EBK-ACC	5	1346610000
UR20-SM-ACC	20	1339920000
PM 2.7/2.6 MC SDR	192	1323700000
PM 2.7/2.6 MC NE WS	960	1323710000
DEK 5/8-11.5 MC SDR	100	1341610000
DEK 5/8-11.5 MC NE WS	500	1341630000
THM UR20 GE *)	1	1429910000
THM UR20 WS *)	1	1429420000
ESD UR20 DIN A4 WS *)	10	1429430000
Replacement parts		
UR20-EM-1335040000-SP	1	1347530000
UR20-BM-SIL-SP	5	1350970000
UR20-PK-1335040000-SP	5	1484100000

*)1 roll = 1000 label = 1 Qty.
*)2 1 sheet = 60 label = 1 Qty.

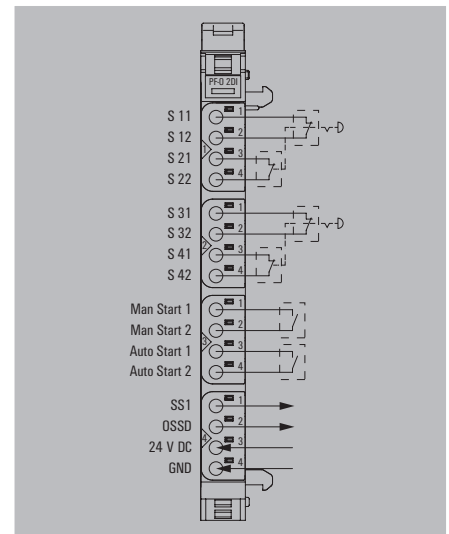

Product standard	IEC 61131-2
EMC	EN 61000
ATEX	EN 60079
UL (in preparation)	UL 508



Let's connect.

Accessories

Potential distribution modules; system accessories

IP 20
A

A wide range of accessory modules is provided for the individual requirements of machine and plant construction. Various potential distribution modules are available for directly supplying sensors with 2-wire, 3-wire or 3-wire+FE connection technology from the remote I/O system. These provide 16 "PUSH IN" potential points and supply your application with each auxiliary potential available. An empty module, where the system bus and voltage supply are looped through, allows you to plan expansion slots in a system and to start these up without any interruptions if required.

UR20-16AUX-0 block diagram example

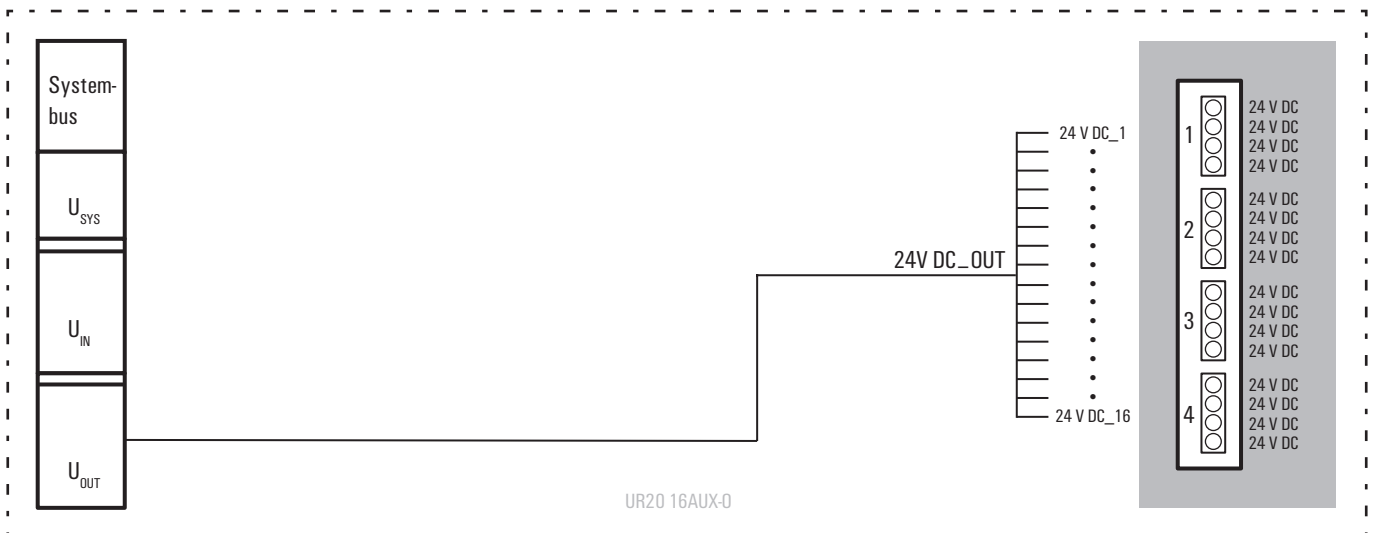

AUX

- Distribution of the various potentials
- Actuator and sensor supply
- 16 "PUSH IN" potential contacts

UR20-16AUX



Technical data

Supply
Voltage supply
General data
Weight
Dimensions (H/W/D)

24 V DC +20 % / - 15 % via Input- or output path / FE
84 g
120 mm (with catch lever) 128 mm x 11,5 mm x 76 mm

Ordering data

Module variants
Potential distribution module

Type	Qty.	Order No.
UR20-16AUX-I	1	1334770000
UR20-16AUX-O	1	1334780000
UR20-16AUX-FE	1	1334790000
UR20-16AUX-GND-I	1	1334800000
UR20-16AUX-GND-O	1	1334810000

Accessories

Replacement parts
Electronics module
Basic module
Plug-in connector unit
Note

Type	Qty.	Order No.
KOSM BHZ5.00	100	1483050000
UR20-EBK-ACC	5	1346610000
UR20-SM-ACC	20	1339920000
PM 2.7/2.6 MC SDR	192	1323700000
PM 2.7/2.6 MC NE WS	960	1323710000
DEK 5/8-11.5 MC SDR	100	1341610000
DEK 5/8-11.5 MC NE WS	500	1341630000
THM UR20 GE * ¹⁾	1	1429910000
THM UR20 WS * ¹⁾	1	1429420000
ESD UR20 DIN A4 WS * ²⁾	10	1429430000
UR20-EM-1334770000-SP	1	1347450000
UR20-EM-1334780000-SP	1	1347470000
UR20-EM-1334790000-SP	1	1347480000
UR20-EM-1334800000-SP	1	1347490000
UR20-EM-1334810000-SP	1	1347500000
UR20-BM-SP	5	1350930000
UR20-PK-1334770000-SP	5	1346450000
UR20-PK-1334790000-SP	5	1346490000
UR20-PK-1334800000-SP	5	1346470000
UR20-PK-1334780000-SP	5	1484080000
UR20-PK-1334810000-SP	5	1484090000

*¹⁾ 1 roll = 1000 label = 1 Qty.
*²⁾ 1 sheet = 60 label = 1 Qty.

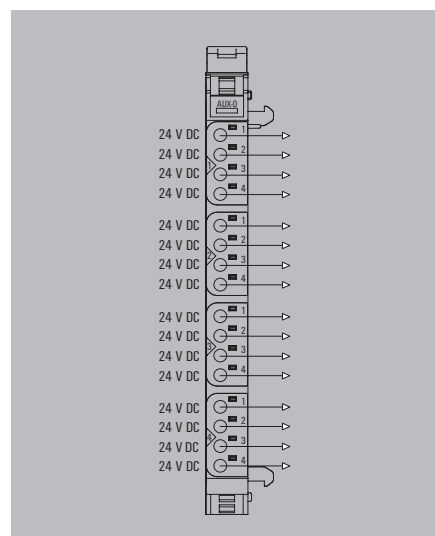

Product standard	IEC 61131-2
EMC	EN 61000
ATEX	EN 60079
UL	UL 508

16AUX-I



Let's connect.

16AUX-O



Let's connect.

16AUX-FE



Let's connect.

16AUX-GND-I



Let's connect.

16AUX GND-O



Let's connect.

Empty module

- Forwarding of system bus and voltage paths
- Space for subsequent expansion
- Basis for all I/O modules

UR20-ES



Technical data

General data

Weight	70 g
Dimensions (H/W/D)	120 mm (with catch lever 128 mm) x 11,5 mm x 76 mm

Ordering data

Module variants

Empty module

Type	Qty.	Order No.
UR20-ES	1	1315770000

Accessories

- Coding elements
- Termination kit
- Swivel marker
- Connection marker for pusher custom printing
- Connection marker for pusher neutral
- Module marker for custom printing
- Module marker for neutral
- Thermotransfer version (Material: Polyester)
- Thermotransfer version (Material: Polyester)
- Paper version for Laserprinter

Replacement parts

- Electronics module
- Basic module
- Plug-in connector unit

Note

Type	Qty.	Order No.
KOSM BHZ5.00	100	1483050000
UR20-EBK-ACC	5	1346610000
UR20-SM-ACC	20	1339920000
PM 2.7/2.6 MC SDR	192	1323700000
PM 2.7/2.6 MC NE WS	960	1323710000
DEK 5/8-11.5 MC SDR	100	1341610000
DEK 5/8-11.5 MC NE WS	500	1341630000
THM UR20 GE * ¹⁾	1	1429910000
THM UR20 WS * ¹⁾	1	1429420000
ESD UR20 DIN A4 WS * ²⁾	10	1429430000

UR20-EM-1315770000-SP	1	1347370000
UR20-BM-SP	5	1350930000
UR20-PK-1315770000-SP	5	1346510000

*¹⁾ 1 roll = 1000 label = 1 Qty.
 *²⁾ 1 sheet = 60 label = 1 Qty.

Product standard	IEC 61131-2
EMC	EN 61000
ATEX	EN 60079
UL	UL 508



Let's connect.

Termination kit

- Includes an end plate and two end brackets

UR20-EBK



Ordering data

Module variants

Termination kit

Type	Qty.	Order No.
UR20-EBK-ACC	5	1346610000

System overview

Below you will find assistance for putting together your system. Please note the maximum number of 64 active modules and the packaging units for the accessories! More detailed technical data and product descriptions can be found here in the catalogue in the corresponding chapter.

At the bottom right-hand side of this page, you will find assistance for supplying the current paths.

1. What field bus are you using?

Bus	Type	Order No.	Page
PROFIBUS	UR20-FBC-PB-DP	1334870000	A.9
PROFINET	UR20-FBC-PN-IRT	1334880000	A.11
EtherCAT	UR20-FBC-EC	1334910000	A.13
Modbus	UR20-FBC-MOD-TCP	1334930000	A.15

2. What signals do you want to process?

Digital inputs	Order No.	Page
UR20-4DI-P	1315170000	A.17
UR20-8DI-P-2W	1315180000	A.18
UR20-8DI-P-3W	1394400000	A.19
UR20-8DI-P-3W-HD	1315190000	A.20
UR20-16DI-P	1315200000	A.21
UR20-16DI-P-PLC-INT	1315210000	A.22
UR20-2DI-P-TS	1460140000	A.23
UR20-4DI-P-TS	1460150000	A.24
UR20-1CNT-100-100	1315570000	A.37
UR20-2CNT-100	1315590000	A.38
UR20-2FCNT-100	1508080000	A.39
Digital outputs		Page
UR20-4DO-P	1315220000	A.27
UR20-4DO-2A	1315230000	A.28
UR20-4DO-PN-2A	1394420000	A.29
UR20-8DO-P	1315240000	A.30
UR20-16DO-P	1315250000	A.31
UR20-16DO-P-PLC-INT	1315270000	A.32
UR20-4RO-SSR-255	1315540000	A.33
UR20-4RO-CO-255	1315550000	A.34
UR20-2PWM-PN-0.5A	1315600000	A.41
UR20-2PWM-PN-2A	1315610000	A.42
Analogue inputs		Page
UR20-4AIUI-16	1315620000	A.45
UR20-4AIUI-16-DIAG	1315690000	A.46
UR20-4AIUI-16-HD	1506920000	A.47
UR20-4AIUI-16-DIAG-HD	1506910000	A.48
UR20-4AIUI-12	1394390000	A.49
UR20-8AIH-PLC-INT	1315670000	A.50
UR20-4AI-RTD-DIAG	1315700000	A.53
UR20-4AI-TC-DIAG	1315710000	A.54
Analogue outputs		Page
UR20-4AO-UI-16	1315680000	A.57
UR20-4AO-UI-16-DIAG	1315730000	A.58
Further functional modules		Page
UR20-PF-0-1DI-SIL	1335030000	A.65
UR20-PF-0-2DI-SIL	1335050000	A.66
UR20-PF-0-2DI-DELAY-SIL	1335040000	A.67

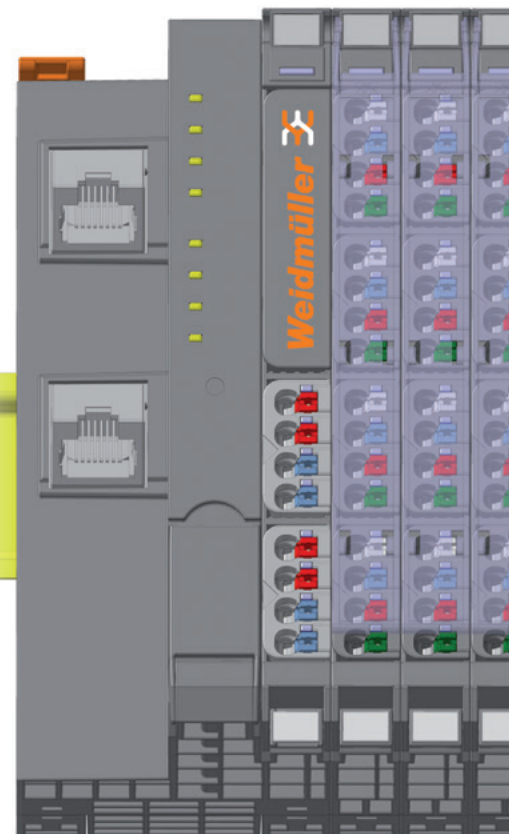

3. Do you need more than 10 A on the input or output path? Then you will need an additional supply! There is a sample calculation at the bottom of this page.

	Order No.	Page
UR20-PF-I	1334710000	A.53
UR20-PF-O	1334740000	A.54

4. AUX and accessories

AUX	Order No.	Page
UR20-16AUX-I	1334770000	A.61
UR20-16AUX-O	1334780000	A.61
UR20-16AUX-FE	1334790000	A.61
UR20-16AUX-GND-I	1334800000	A.61
UR20-16AUX-GND-O	1334810000	A.61
Accessories		Page
End bracket	1346610000	A.61
Swivel marker	1339920000	A.61
Connection marker for pusher custom printing	1323700000	A.61
Connection marker for pusher neutral	1323710000	A.61
Module marker for custom printing	1341610000	A.61
Module marker for neutral	1341630000	A.61
Empty module	1315770000	A.62
Thermotransfer version (Material: Polyester)	1429910000	A.61
Thermotransfer version (Material: Polyester)	1429420000	A.61
Paper version for Laserprinter	1429430000	A.61



The additional supply calculation is different for each application. Simultaneity factors and current requirement must be known. To assist you, we have produced the example shown here in a simplified form.

Our example uses a row of 8-DO modules, i.e. units which can hold four actuator connections each. The actual current needed and therefore the position for a power-feed module to supply the current path can be determined from the mathematical combination of current requirement and simultaneity factor. Please note that u-remote provides an input and an output current path. Both must be included in the additional supply calculation. The system voltage doesn't have to be taken into account.

Sample calculation

Module no.	Module type	Current requirement of connected devices (A)	Simultaneity factor	Current following calculation of simultaneity factor per module	Current requirement of system - cumulative	Current requirement of system - cumulative with UR20-PF-O
1st module	UR20-8DO-P	0.5	0.5	0.25	0.25	0.25
2nd module	UR20-8DO-P	0.3	0.5	0.15	0.4	0.4
3rd module	UR20-8DO-P	2.0	0.7	1.4	1.8	1.8
4th module	UR20-8DO-P	2.0	0.5	1	2.8	2.8
5th module	UR20-8DO-P	2.0	0.3	2	4.8	4.8
6th module	UR20-8DO-P	0.5	0.2	0.1	4.9	4.9
7th module	UR20-8DO-P	1.0	0.1	0.75	5.65	5.65
8th module	UR20-8DO-P	1.0	0.2	0.2	5.85	5.85
9th module	UR20-8DO-P	1.2	0.5	0.6	6.45	6.45
10th module	UR20-8DO-P	2.0	1.0	2	8.45	8.45
	UR20-PF-O					
11th module	UR20-8DO-P	2.0	1.0	2	10.45	2
12th module	UR20-8DO-P	3.0	1.0	1	11.45	3
13th module	UR20-8DO-P	2.0	1.0	2	13.45	5

Current requirement exceeds 10 A!
The output current path therefore needs an additional supply before the 11th module.

10 A supplied by the UR20-PF-O module. The 1.55 A calculated as remaining after the 10th module must not be added to the 10 A after the UR20-PF-O module!

Modular Communication. Robust. SAI Active.

IP 67

B



When constructing machines and plants, sensors and actuators have to be connected to the control unit such that all these signals can be collected locally using fieldbuses.

The SAI Active product family solves this problem by means of IP 67 protected encapsulation at the very point where the sensors and actuators are located. In the variants with a sub-bus system, this is done very flexibly and in a wide range of applications.



IP 67

IP 67	Introduction	B.2
	Quick select - SAI Active	B.6
	SAI Active Universal - Overview	B.8
	SAI Active Universal - PROFIBUS-DP	B.10
	SAI Active Universal - CANopen	B.14
	SAI Active Universal - DeviceNet™	B.18
	SAI Active Universal Pro - Overview	B.22
	SAI Active Universal Pro	B.24
	Accessories for sensor cables	B.34

Remote I/O system in class of protection IP 67 for SAI Active family

Flexible sensor/actuator coupling to control systems in IP 67 area in industrial environment

IP 67

B

In both machine and plant construction, sensors and actuators from the entire machine have to be connected to the control unit. Depending on the machine, the reach, but also the volume of these signals may be very large so that fieldbuses and IO systems can be used to collect the signals locally.

The SAI Active product family solves this problem by means of IP 67 protected encapsulation at the very point where the sensors and actuators are located. In the variants with a sub-bus system, this is done very flexibly and in a wide range of applications.

Direct incorporation in the SYS programming environment, rapid definition of causes in the event of faults and a very narrow and lightweight design are the characteristics which make this system unique on the market.

Rapid fault rectification

Rapid definition of causes in the event of faults by providing extended diagnostic data to the control unit and on the device itself.



Efficient engineering

Direct incorporation and configuration in the standard PLC engineering systems (such as Step 7, RS-Logix, CX-Configurator, MELSEC, ...)



Universal adaptation

The analogue inputs and outputs are freely configurable in the different analogue value ranges.

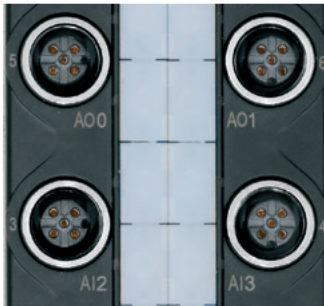

50 % reduced costs through flexible sub-bus concept

Sub-bus length of up to 50 m with up to 15 slaves per sub-bus enables an extremely flexible setup.

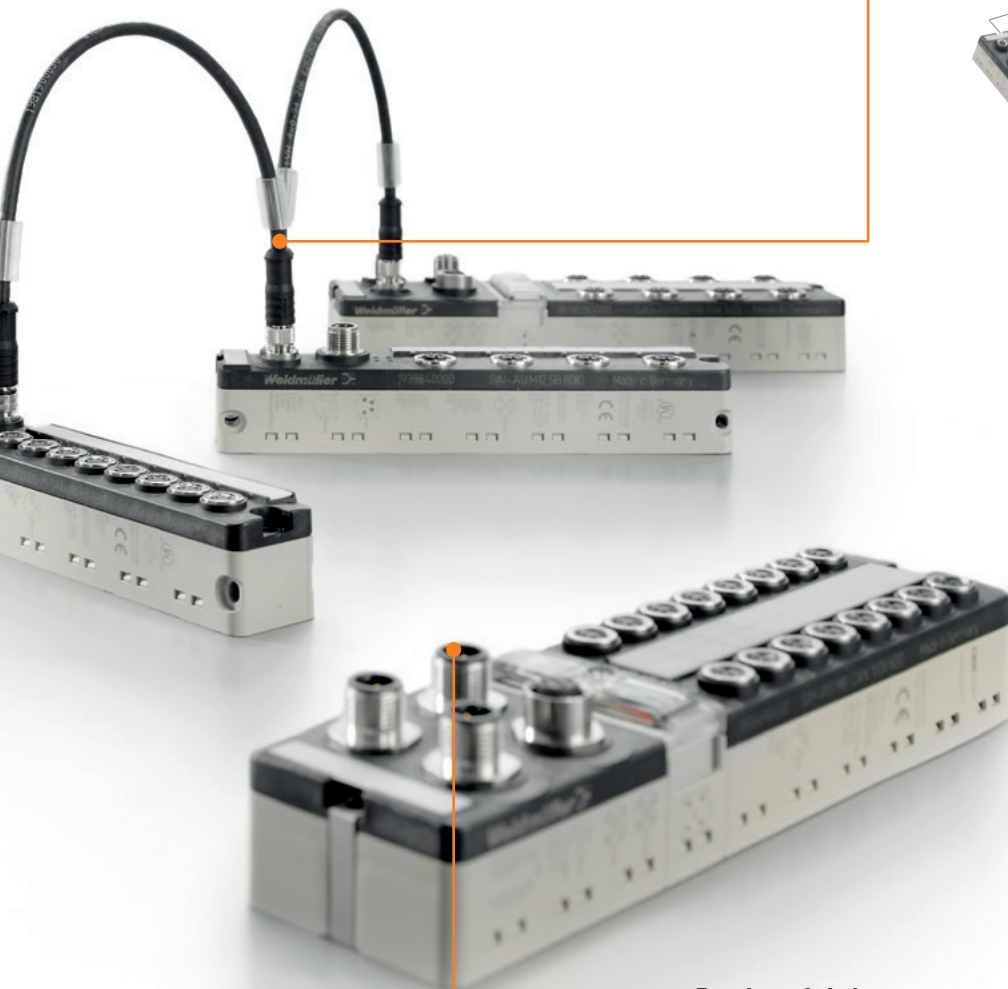
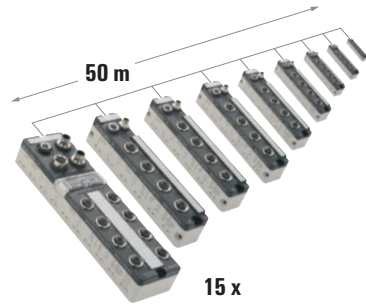

Remote I/O system as complete system on the panel

An extremely wide range of sensor and actuator cables, fieldbus cables and customisable plug-in connectors round off the range.



Freedom of choice

Support for all common field bus systems such as PROFIBUS, DeviceNet™, CANopen, RS232.



Challenging production tasks present you with motion and distribution

We present SAI for a secure processing of your sensor and actuator signals

Let's connect.

IP 67

B



Complex production processes mean that you have to co-ordinate lots of individual processing stages. Numerous sensors and actuators throughout the production facility are connected with the central control system. And in many cases, you have to bridge huge distances and process a large number of different signals.

Weidmüller's SAI Active product range equips you for this production process chain in a practical way. Thanks to IP 67-rated encapsulation, the remote I/O systems can be positioned directly where sensors and actuators are active. The SAI-PRO variants with sub-bus system also greatly increase your flexibility: the sub-bus system SAI-PRO can be extended to a length of up to 50 m with up to 15 modules. Up to 120 inputs or outputs are therefore possible on one fieldbus node.

Various versions of encapsulated SAI cables make the sensors and actuators accessible. You can also route fieldbus cables straight from the switch cabinet with the energy supply lines using modular, heavy-duty plug-in connectors of the RockStar® concept. This allows you to integrate several stages of production into your production facility with just one single module.

Other benefits of the SAI family include a direct interface to your PLC programming environment and precise error analyses with visual status display. Let's connect.

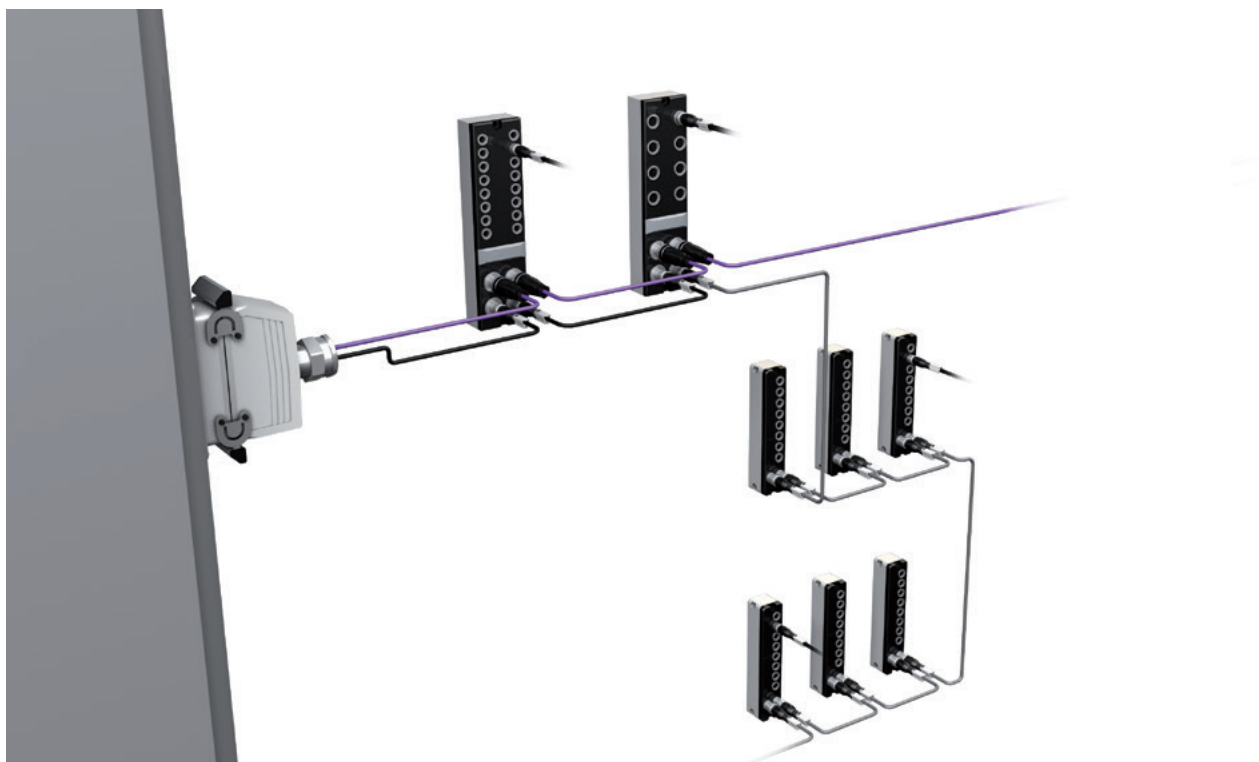

Remote I/O IP 67 SAI Active

- Efficient engineering by direct integration into standard PLC system engineering
- Rapid identification of failure causes by providing enhanced diagnostic data
- 50 % cost reduction by flexible sub-bus concept
- Analogue inputs and outputs have freely configurable analog value

Sensor Actuator Cabling

- Broad range of leadership qualities
- Free attachable connectors with screw connection up to crimp versions
- Customised versions and lengths from 1 piece
- 360 degree shielding
- Many types from stock

Selection table

Order No.	Product designation	Connection system			Communication						
		M8	M12	PROFIBUS DP	CANopen	DeviceNet™	Modbus ASCII (RS 232 / USB)	Modbus TCP	EtherNet/IP	Subbus	Wireless
SAI Active Universal											
1906550000	SAI-AU M8 PB 16DI	X		X							
1906640000	SAI-AU M8 PB 16DI/8DO	X		X							
1975450000	SAI-AU M8 PB 8DI8DO 2A	X		X							
1890020000	SAI-AU M12 PB 16DI		X	X							
1890010000	SAI-AU M12 PB 16DI/8DO		X	X							
1968220000	SAI-AU M12 PB 8DI8DO 2A		X	X							
1890000000	SAI-AU M12 PB AI/AO/DI		X	X							
1906680000	SAI-AU M8 CAN 16DI	X			X						
1906690000	SAI-AU M8 CAN 16DI/8DO	X			X						
1906650000	SAI-AU M12 CAN 16DI		X		X						
1906660000	SAI AU M12 CAN 16DI/8DO		X		X						
1906670000	SAI-AU M12 CAN AI/AO/DI		X		X						
1906730000	SAI-AU M8 DN 16DI	X				X					
1906740000	SAI AU M8 DN 16DI/8DO	X				X					
1906700000	SAI-AU M12 DN 16DI		X			X					
1906710000	SAI AU M12 DN 16DI/8DO		X			X					
1906720000	SAI-AU M12 DN AI/AO/DI		X			X					
SAI Active Universal Pro											
1024310000	SAI-AU M8 PB GW 16DI	X		X						X	
1938550000	SAI-AU M12 PB GW 16DI		X	X						X	
1938570000	SAI-AU M12 DN GW 16DI		X			X				X	
1938600000	SAI-AU M8 SB 8DI	X								X	
1938660000	SAI-AU M8 SB 8DO 2A	X								X	
1938630000	SAI-AU M8 SB 8DIO	X								X	
1938610000	SAI-AU M12 SB 8DI		X							X	
1938680000	SAI-AU M12 SB 8DO 2A		X							X	
1938640000	SAI-AU M12 SB 8DIO		X							X	
1938690000	SAI-AU M12 SB 4AI		X							X	
1938700000	SAI-AU M12 SB 4AO		X							X	
1938730000	SAI-AU M12 SB 2Counter		X							X	
1938720000	SAI-AU M12 SB 4Thermo		X							X	
1938710000	SAI-AU M12 SB 4PT100		X							X	

	Inputs					Outputs				Supply voltage feed circuits	Special characteristics	Page
	Digital	Analogue	Counter	TC	RTD	Digital	Output current	Analogue	Output range			
	16									2		B.10
	max. 16, min. 8 (can be configured)					max. 8, min. 0 (can be configured)	0.5 A			4	- Max. I/O channels = 16	B.10
	8					8	2 A			4	- Max. total current, output = 8 A	B.10
	16									2		B.10
	max. 16, min. 8 (can be configured)					max. 8, min. 0 (can be configured)	0.5 A			1	- Max. I/O channels = 16	B.10
	8					8	2 A			2	- Max. total current, output = 8 A	B.10
	4	4						2	-10...+10 V, 0...+10 V, 0...20 mA, 4...20 mA	2		B.11
	16									2		B.14
	max. 16, min. 8 (can be configured)					max. 8, min. 0 (can be configured)	0.5 A			4	- Max. I/O channels = 16	B.14
	16									2		B.14
	max. 16, min. 8 (can be configured)					max. 8, min. 0 (can be configured)	0.5 A			4	- Max. I/O channels = 16	B.14
	4	4						2	-10...+10 V, 0...+10 V, 0...20 mA, 4...20 mA	2		B.15
	16									2		B.18
	max. 16, min. 8 (can be configured)					max. 8, min. 0 (can be configured)	0.5 A			4	- Max. I/O channels = 16	B.18
	16									2		B.18
	max. 16, min. 8 (can be configured)					max. 8, min. 0 (can be configured)	0.5 A			4	- Max. I/O channels = 16	B.18
	4	4						2	-10...+10 V, 0...+10 V, 0...20 mA, 4...20 mA	2		B.19
	16									2		B.24
	16									2		B.24
	16									2		B.26
	8											B.30
						8	2 A			2	- Max. total current, output = 8 A	B.30
	max. 8, min. 0 (can be configured)					max. 8, min. 0 (can be configured)	0.5 A			2	- Max. I/O channels = 8	B.30
	8										- Max. total current, output = 4 A	B.30
						8	2 A			2	- Max. I/O channels = 8	B.30
											- Max. total current, output = 4 A	B.30
	max. 8, min. 0 (can be configured)					max. 8, min. 0 (can be configured)	0.5 A			2	- Max. I/O channels = 8	B.30
		4										B.31
								4	-10...+10 V, 0...+10 V, 0...20 mA, 4...20 mA			B.31
			2							2		B.32
				4								B.33
					4							B.34

SAI Active Universal

IP 67

Compact, basic versions of the Remote I/O system with IP 67 protection

B The SAI Active Universal consists of basic, compact designed variants that include a variety of modules for digital and analogue inputs and outputs. The housing has a sturdy construction in compliance with strict industrial requirements. It is resistant against aggressive materials, vibration, shock, temperature, water and dust.

The high quality connection system uses conventional, standardised M8 and M12 connectors with standards-compliant coding. They ensure a reliable wiring process with less risk of errors. Two M12 connections for the fieldbus allow for a continuous bus installation without any additional T-distributor. The functional earth connection is automatically created when installing on a metallic earthed base.





4 independent voltage circuits

The modules can be supplied with up to four different voltage potentials. The module voltage can be simultaneously used for the inputs. In addition, up to three feed points are available for outputs; these can be switched off individually depending on the application requirements. Plug in cross connectors can be used to merge voltage potentials on the module.



Efficient diagnostics and status alerts

The status of the I/Os is shown directly on the module using arrow icons. The arrows point to the label and the plug in position. Up to seven status LEDs are available for displaying additional information about the power supply, fieldbus status and group diagnostics. The information is simultaneously transmitted to the controller unit via the bus system.

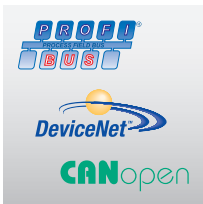

Freedom of choice

Total compliance with many industrial fieldbus standards: this permits integration with all conventional controllers so that the modules can be used in practically all applications. SAI Active Universal supports PROFIBUS-DP, CANopen, DeviceNet™ communication protocols.



A wide variety of variants

All SAI Active modules with digital inputs or digital outputs are optionally available with standard M8 or M12 connection systems. For modules in the 16DI/8DO series, the configuration can be customised to fit the application so that anywhere between 16DI to 8DI/8DO can be used. Output cables with up to 2 A per channel are used to connect almost any load. Analogue modules can be configured flexibly for the current of voltage outputs.

PROFIBUS-DP

Remote I/O for digital signal processing



SAI-AU



SAI-AU



Ordering data

Module variants
16 Digital In; 16 Digital In / 8 Digital Out
16 Digital In; 16 Digital In / 8 Digital Out
8 Digital In / 8 Digital Out
8 Digital In / 8 Digital Out

Note

Technical data

Connections
Fieldbus (BUS-IN)
Fieldbus (BUS-OUT)
Supply voltage (AUX-IN)
Supply voltage (AUX-OUT)
I/O connections
Voltage supply
Operating voltage
Contact load
Max. total current module
Digital inputs
Permitted input voltage
Input current, low
Input current, high
Input current, low
Input current, high
Input filter
Digital outputs
max. current-carrying capacity per output signal
Switching frequency load (resistive / inductive / inrush)
Short-circuit-proof
Output voltage, low
Output voltage, high
Max. total current of outputs
Fieldbus
Bus system
Transmission rate
Addressing
System integration
General data
L x W x H
Earth
Protection degree
Operating temperature
Storage temperature
Housing main material / UL 94 flammability rating
Certificate

Type	Qty.	Order No.
SAI-AU M8 PB 16DI	1	1906550000
SAI-AU M12 PB 16DI	1	1890020000

1x M12 plug 5-pole, B-coded
1x M12 female 5-pole, B-coded
1x M12 plug 5-pole, A-coded
1x M12 female 5-pole, A-coded
16 x M8 socket 3-pole / 8 x M12 socket 5-pole, A-coded
24 V (18 V DC ... 30 V DC)
Per PIN max. 4 A
10 A
-30 V to +30 V (protected against polarity reversal)
< 15 mA in accordance with EN 61131-2 Type 1
2 mA to 15 mA in accordance with EN 61131-2 Type 1
< 15 mA in accordance with EN 61131-2 Type 1
2 mA to 15 mA in accordance with EN 61131-2 Type 1
3 ms
PROFIBUS-DP
Max. 12 Mbit/s (automatic detection)
Via rotary coding switch (1 - 126)
GSD file (Device-specific for each module)
210 mm / 54 mm / 32 mm
< 400 g
IP 67
0 °C...+60 °C
-25 °C...+85 °C
Pocan, PBT / V-0
CE, cULus

Type	Qty.	Order No.
SAI-AU M8 PB 16DI/8DO	1	1906640000
SAI-AU M12 PB 16DI/8DO	1	1890010000
SAI-AU M8 PB 8DI8DO 2A	1	1975450000
SAI-AU M12 PB 8DI8DO 2A	1	1968220000

1x M12 plug 5-pole, B-coded
1x M12 female 5-pole, B-coded
2x M12 plug 5-pole, A-coded
16 x M8 socket 3-pole / 8 x M12 socket 5-pole, A-coded
24 V (18 V DC ... 30 V DC)
Per PIN max. 4 A
10 A
-30 V to +30 V (protected against polarity reversal)
< 15 mA in accordance with EN 61131-2 Type 1
2 mA to 15 mA in accordance with EN 61131-2 Type 1
< 15 mA in accordance with EN 61131-2 Type 1
2 mA to 15 mA in accordance with EN 61131-2 Type 1
3 ms
0.5 A, 2 A
max. 100 Hz / max. 1 Hz / max. 8 Hz
Yes, cut-off for short circuit and error message
0 V DC
Supply voltage less 0.7 V DC
7 A, 8 A
PROFIBUS-DP
Max. 12 Mbit/s (automatic detection)
Via rotary coding switch (1 - 126)
GSD file (Device-specific for each module)
210 mm / 54 mm / 32 mm
< 400 g
IP 67
0 °C...+60 °C
-25 °C...+85 °C
Pocan, PBT / V-0
CE, cULus

Note

PROFIBUS-DP

Remote I/O for digital and
analogue signal processing



SAI-AU



Ordering data

Module variants
4 Analogue In / 2 Analogue Out / 4 Digital In
Note

Type	Qty.	Order No.
SAI-AU M12 PB AI/AO/DI	1	189000000

Technical data

Connections	
Fieldbus (BUS-IN)	1x M12 plug 5-pole, B-coded
Fieldbus (BUS-OUT)	1x M12 female 5-pole, B-coded
Supply voltage (AUX-IN)	1x M12 plug 5-pole, A-coded
Supply voltage (AUX-OUT)	1x M12 female 5-pole, A-coded
I/O connections	8 x M12 socket 5-pole, A-coded
Voltage supply	
Operating voltage	24 V (18 V DC ... 30 V DC)
Contact load	Per PIN max. 4 A
Max. total current module	10 A
Digital inputs	
Permitted input voltage	-30 V to +30 V (protected against polarity reversal)
Input current, low	< 15 mA in accordance with EN 61131-2 Type 1
Input current, high	2 mA to 15 mA in accordance with EN 61131-2 Type 1
Input current, low	< 15 mA in accordance with EN 61131-2 Type 1
Input current, high	2 mA to 15 mA in accordance with EN 61131-2 Type 1
Input filter	3 ms
Analogue inputs	
Measurement range	-10 V ... +10 V, 0 V ... 10V, 0 ... 20 mA, 4...20 mA
Maximum input voltage in relation to GND	35 V
Input resistance (load)	<125 Ohm
Max. input current (differential)	-50 mA to +50 mA (protected against polarity reversal)
Short-circuit-proof	Yes
Resolution / Accuracy	12-bit / < 0.2 %
Analogue outputs	
Measurement range	-10 V ... +10 V, 0 V ... 10V, 0 ... 20 mA, 4...20 mA
Output interval	5 ms to 250 ms (can be configured)
Short-circuit-proof	Yes
Resolution / Accuracy	12-bit / < 0.2 %
Fieldbus	
Bus system	PROFIBUS-DP
Transmission rate	Max. 12 Mbit/s (automatic detection)
Addressing	Via rotary coding switch (1 - 126)
System integration	GSD file (Device-specific for each module)
General data	
L x W x H	210 mm / 54 mm / 32 mm
Earth	< 400 g
Protection degree	IP 67
Operating temperature	0 °C...+60 °C
Storage temperature	-25 °C...+85 °C
Housing main material / UL 94 flammability rating	Pocan, PBT / V-0
Certificate	CE, cULus

Note

Engineering tables for PROFIBUS



When planning the automation of a facility, you must have a wide variety of components available.

These engineering tables list all the components required for wiring up the SAI Active modules.

PROFIBUS modules



PROFIBUS accessories



Sensor/actuator accessories

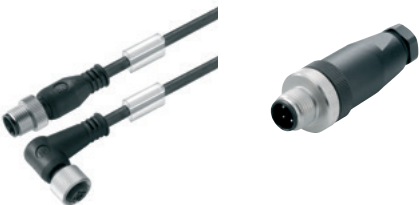

Markers



Protective caps



Ordering data

Description	Type	Qty.	Order No.
PROFIBUS modules			
16 Digital In	SAI-AU M12 PB 16DI	1	1890020000
16 Digital In / 8 Digital Out	SAI-AU M12 PB 16DI/8DO	1	1890010000
4 Analogue In / 2 Analogue Out / 4 Digital In	SAI-AU M12 PB AI/AO/DI	1	1890000000
8 Digital In / 8 Digital Out	SAI-AU M12 PB 8DI/8DO 2A	1	1968220000
16 Digital In	SAI-AU M8 PB 16DI	1	1906550000
16 Digital In / 8 Digital Out	SAI-AU M8 PB 16DI/8DO	1	1906640000
8 Digital In / 8 Digital Out	SAI-AU M8 PB 8DI/8DO 2A	1	1975450000

PROFIBUS accessories

PROFIBUS cables with female plug and male plug			*)
PROFIBUS cables with female plug and other side open			*)
PROFIBUS cables with male plug and other side open			*)

PROFIBUS plug-in connector

*)

PROFIBUS terminating resistor

SAIEND PB M12 4P B-COD

1

1784770000

Sensor/actuator accessories

Sensor-actuator cables			*)
------------------------	--	--	----

Sensor-actuator plugs

*)

Markers

Semi-transparent markers for PrintJet printing	ESG 8/13.5/43.3 SAI AU	5	1912130000
--	------------------------	---	------------

Protective caps

M8 Dust cap (Sensor connections)	SAI-SK M8	50	1802760000
M12 Dust cap (Sensor connections)	SAI-SK	30	9456050000
M12 Dust cap (Bus-out and power-out)	SAI-SK-M12-UNI	20	2330260000
M12 Dust cap (Bus-in and power-in)	SAI-SK plug M12	50	1781520000

Note: *) Can be found in our latest catalogue 8, signal and power transmission, order no. 1366750000

CANopen
Remote I/O for digital
signal processing



IP 67

B

Ordering data

Module variants
16 Digital In; 16 Digital In / 8 Digital Out
16 Digital In; 16 Digital In / 8 Digital Out

Technical data

Connections
Fieldbus (BUS-IN)
Fieldbus (BUS-OUT)
Supply voltage (AUX-IN)
Supply voltage (AUX-OUT)
I/O connections
Voltage supply
Operating voltage
Contact load
Max. total current module
Digital inputs
Permitted input voltage
Input current, low
Input current, high
Input current, low
Input current, high
Input filter
Digital outputs
max. current-carrying capacity per output signal
Switching frequency load (resistive / inductive / inrush)
Short-circuit-proof
Output voltage, low
Output voltage, high
Max. total current of outputs
Fieldbus
Bus system
Transmission rate
Addressing
System integration
General data
L x W x H
Earth
Protection degree
Operating temperature
Storage temperature
Housing main material / UL 94 flammability rating
Certificate

Note

SAI-AU



Type	Qty.	Order No.
SAI-AU M8 CAN 16DI	1	1906680000
SAI-AU M12 CAN 16DI	1	1906650000

1x M12 plug 5-pole, A-coded
1x M12 female 5-pole, A-coded
1x M12 plug 5-pole, A-coded
1x M12 female 5-pole, A-coded
16 x M8 socket 3-pole / 8 x M12 socket 5-pole, A-coded
24 V (18 V DC ... 30 V DC)
Per PIN max. 4 A
8 A
-30 V to +30 V (protected against polarity reversal)
< 15 mA in accordance with EN 61131-2 Type 1
2 mA to 15 mA in accordance with EN 61131-2 Type 1
< 15 mA in accordance with EN 61131-2 Type 1
2 mA to 15 mA in accordance with EN 61131-2 Type 1
3 ms
CANopen
Max. 1 Mbit/s (automatic detection)
Via rotary coding switch (1 - 127)
EDS file (Device-specific for each module)
210 mm / 54 mm / 32 mm
< 400 g
IP 67
0 °C...+60 °C
-25 °C...+85 °C
Pocan, PBT / V-0
CE, cULus

Note

SAI-AU



Type	Qty.	Order No.
SAI-AU M8 CAN 16DI/8DO	1	1906690000
SAI-AU M12 CAN 16DI/8DO	1	1906660000

1x M12 plug 5-pole, A-coded
1x M12 female 5-pole, A-coded
2x M12 plug 5-pole, A-coded
16 x M8 socket 3-pole / 8 x M12 socket 5-pole, A-coded
24 V (18 V DC ... 30 V DC)
Per PIN max. 4 A
8 A
-30 V to +30 V (protected against polarity reversal)
< 15 mA in accordance with EN 61131-2 Type 1
2 mA to 15 mA in accordance with EN 61131-2 Type 1
< 15 mA in accordance with EN 61131-2 Type 1
2 mA to 15 mA in accordance with EN 61131-2 Type 1
3 ms
0.5 A, 2 A
max. 100 Hz / max. 1 Hz / max. 8 Hz
Yes, cut-off for short circuit and error message
0 V DC
Supply voltage less 0.7 V DC
7 A, 8 A
CANopen
Max. 1 Mbit/s (automatic detection)
Via rotary coding switch (1 - 127)
EDS file (Device-specific for each module)
210 mm / 54 mm / 32 mm
< 400 g
IP 67
0 °C...+60 °C
-25 °C...+85 °C
Pocan, PBT / V-0
CE, cULus

Note

CANopen

Remote I/O for digital and analogue signal processing

SAI-AU



Ordering data

Module variants
4 Analogue In / 2 Analogue Out / 4 Digital In
Note

Type	Qty.	Order No.
SAI-AU M12 CAN AI/AO/DI	1	1906670000

Technical data

Connections	
Fieldbus (BUS-IN)	1x M12 plug 5-pole, A-coded
Fieldbus (BUS-OUT)	1x M12 female 5-pole, A-coded
Supply voltage (AUX-IN)	1x M12 plug 5-pole, A-coded
Supply voltage (AUX-OUT)	1x M12 female 5-pole, A-coded
I/O connections	
Voltage supply	
Operating voltage	24 V (18 V DC ... 30 V DC)
Contact load	Per PIN max. 4 A
Max. total current module	8 A
Digital inputs	
Permitted input voltage	-30 V to +30 V (protected against polarity reversal)
Input current, low	< 15 mA in accordance with EN 61131-2 Type 1
Input current, high	2 mA to 15 mA in accordance with EN 61131-2 Type 1
Input current, low	< 15 mA in accordance with EN 61131-2 Type 1
Input current, high	2 mA to 15 mA in accordance with EN 61131-2 Type 1
Input filter	3 ms
Digital outputs	
max. current-carrying capacity per output signal	
Switching frequency load (resistive / inductive / inrush)	
Short-circuit-proof	
Output voltage, low	
Output voltage, high	
Max. total current of outputs	
Fieldbus	
Bus system	CANopen
Transmission rate	Max. 1 Mbit/s (automatic detection)
Addressing	Via rotary coding switch (1 - 127)
System integration	EDS file (Device-specific for each module)
General data	
L x W x H	210 mm / 54 mm / 32 mm
Earth	< 400 g
Protection degree	IP 67
Operating temperature	0 °C...+60 °C
Storage temperature	-25 °C...+85 °C
Housing main material / UL 94 flammability rating	Pocan, PBT / V-0
Certificate	CE, cULus

Note

Engineering tables for CANopen

When planning the automation of a facility, you must have a wide variety of components available.

These engineering tables list all the components required for wiring up the SAI Active modules.

CANopen modules



CANopen accessories



Sensor/actuator accessories

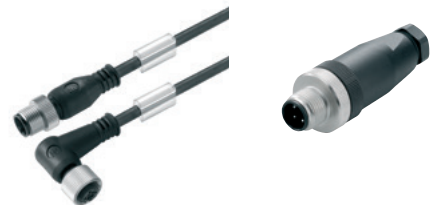

Markers



Protective caps



Ordering data

Description	Type	Qty.	Order No.
CANopen modules			
16 Digital In	SAI-AU M12 CAN 16DI	1	1906650000
16 Digital In / 8 Digital Out	SAI AU M12 CAN 16DI/8DO	1	1906660000
4 Analogue In / 2 Analogue Out / 4 Digital In	SAI-AU M12 CAN AI/AO/DI	1	1906670000
16 Digital In	SAI-AU M8 CAN 16DI	1	1906680000
16 Digital In / 8 Digital Out	SAI-AU M8 CAN 16DI/8DO	1	1906690000

CANopen accessories

CANopen cables with female plug and male plug	*)
CANopen cables with female plug and other side open	*)
CANopen cables with male plug and other side open	*)

CANopen plug-in connector

*)

CANopen terminating resistor

SAIEND CAN-M12 5P A-COD

1

1784760000

Sensor/actuator accessories

Sensor-actuator cables	*)
------------------------	----

Sensor-actuator plugs

*)

Markers

Semi-transparent markers for PrintJet printing	ESG 8/13.5/43.3 SAI AU	5	1912130000
--	------------------------	---	------------

Protective caps

M8 Dust cap (Sensor connections)	SAI-SK M8	50	1802760000
M12 Dust cap (Sensor connections)	SAI-SK	30	9456050000
M12 Dust cap (Bus-out and power-out)	SAI-SK-M12-UNI	20	2330260000
M12 Dust cap (Bus-in and power-in)	SAI-SK plug M12	50	1781520000

Note: *) Can be found in our latest catalogue 8, signal and power transmission, order no. 1366750000

DeviceNet™
Remote I/O for digital
signal processing



IP 67

B

Ordering data

Module variants	
16 Digital In; 16 Digital In / 8 Digital Out	
16 Digital In; 16 Digital In / 8 Digital Out	

Note

Technical data

Connections	
Fieldbus (BUS-IN)	
Fieldbus (BUS-OUT)	
Supply voltage (AUX-IN)	
Supply voltage (AUX-OUT)	
I/O connections	
Voltage supply	
Operating voltage	
Contact load	
Max. total current module	
Digital inputs	
Permitted input voltage	
Input current, low	
Input current, high	
Input current, low	
Input current, high	
Input filter	
Digital outputs	
max. current-carrying capacity per output signal	
Switching frequency load (resistive / inductive / inrush)	
Short-circuit-proof	
Output voltage, low	
Output voltage, high	
Max. total current outputs	
Fieldbus	
Bus system	
Transmission rate	
Addressing	
System integration	
General data	
L x W x H	
Earth	
Protection degree	
Operating temperature	
Storage temperature	
Housing main material / UL 94 flammability rating	
Certificate	

Note

SAI-AU



Type	Qty.	Order No.
SAI-AU M8 DN 16DI	1	1906730000
SAI-AU M12 DN 16DI	1	1906700000

1x M12 plug 5-pole, A-coded
1x M12 female 5-pole, A-coded
1x M12 plug 5-pole, A-coded
1x M12 female 5-pole, A-coded
16 x M8 socket 3-pole / 8 x M12 socket 5-pole, A-coded
24 V (18 V DC ... 30 V DC)
Per PIN max. 4 A
8 A
-30 V to +30 V (protected against polarity reversal)
< 15 mA in accordance with EN 61131-2 Type 1
2 mA to 15 mA in accordance with EN 61131-2 Type 1
< 15 mA in accordance with EN 61131-2 Type 1
2 mA to 15 mA in accordance with EN 61131-2 Type 1
3 ms
DeviceNet™
Max. 500 kBit/s (automatic detection)
Via rotary coding switch (0 - 63)
EDS file (Device-specific for each module)
210 mm / 54 mm / 32 mm
< 400 g
IP 67
0 °C...+60 °C
-25 °C...+85 °C
Pocan, PBT / V-0
CE, cULus

SAI-AU



Type	Qty.	Order No.
SAI-AU M8 DN 16DI/8DO	1	1906740000
SAI-AU M12 DN 16DI/8DO	1	1906710000

1x M12 plug 5-pole, A-coded
1x M12 female 5-pole, A-coded
2x M12 plug 5-pole, A-coded
16 x M8 socket 3-pole / 8 x M12 socket 5-pole, A-coded
24 V (18 V DC ... 30 V DC)
Per PIN max. 4 A
8 A
-30 V to +30 V (protected against polarity reversal)
< 15 mA in accordance with EN 61131-2 Type 1
2 mA to 15 mA in accordance with EN 61131-2 Type 1
< 15 mA in accordance with EN 61131-2 Type 1
2 mA to 15 mA in accordance with EN 61131-2 Type 1
3 ms
0.5 A, 2 A
max. 100 Hz / max. 1 Hz / max. 8 Hz
Yes, cut-off for short circuit and error message
0 V DC
Supply voltage less 0.7 V DC
7 A
DeviceNet™
Max. 500 kBit/s (automatic detection)
Via rotary coding switch (0 - 63)
EDS file (Device-specific for each module)
210 mm / 54 mm / 32 mm
< 400 g
IP 67
0 °C...+60 °C
-25 °C...+85 °C
Pocan, PBT / V-0
CE, cULus

Note

DeviceNet™
Remote I/O for digital and
analogue signal processing



SAI-AU



Ordering data

Module variants
4 Analogue In / 2 Analogue Out / 4 Digital In
Note

Type	Qty.	Order No.
SAI-AU M12 DN AI/AO/DI	1	1906720000

Technical data

Connections	
Fieldbus (BUS-IN)	1x M12 plug 5-pole, A-coded
Fieldbus (BUS-OUT)	1x M12 female 5-pole, A-coded
Supply voltage (AUX-IN)	1x M12 plug 5-pole, A-coded
Supply voltage (AUX-OUT)	1x M12 female 5-pole, A-coded
I/O connections	8 x M12 socket 5-pole, A-coded
Voltage supply	
Operating voltage	24 V (18 V DC ... 30 V DC)
Contact load	Per PIN max. 4 A
Max. total current module	8 A
Digital inputs	
Permitted input voltage	-30 V to +30 V (protected against polarity reversal)
Input current, low	< 15 mA in accordance with EN 61131-2 Type 1
Input current, high	2 mA to 15 mA in accordance with EN 61131-2 Type 1
Input current, low	< 15 mA in accordance with EN 61131-2 Type 1
Input current, high	2 mA to 15 mA in accordance with EN 61131-2 Type 1
Input filter	3 ms
Analogue inputs	
Measurement range	-10 V ... +10 V, 0 V ... 10 V, 0 ... 20 mA, 4...20 mA
Maximum input voltage in relation to GND	35 V
Input resistance (load)	<125 Ohm
Max. input current (differential)	-50 mA to +50 mA (protected against polarity reversal)
Short-circuit-proof	Yes
Resolution / Accuracy	12-bit / < 0.2 %
Analogue outputs	
Measurement range	-10 V ... +10 V, 0 V ... 10 V, 0 ... 20 mA, 4...20 mA
Output interval	5 ms to 250 ms (can be configured)
Short-circuit-proof	Yes
Resolution / Accuracy	12-bit / < 0.2 %
Fieldbus	
Bus system	DeviceNet™
Transmission rate	Max. 500 kBit/s (automatic detection)
Addressing	Via rotary coding switch (0 - 63)
System integration	EDS file (Device-specific for each module)
General data	
L x W x H	210 mm / 54 mm / 32 mm
Earth	< 400 g
Protection degree	IP 67
Operating temperature	0 °C...+60 °C
Storage temperature	-25 °C...+85 °C
Housing main material / UL 94 flammability rating	Pocan, PBT / V-0
Certificate	CE, cULus

Note

Note

Engineering tables for DeviceNet™

When planning the automation of a facility, you must have a wide variety of components available.

These engineering tables list all the components required for wiring up the SAI Active modules.

DeviceNet™ modules



DeviceNet™ accessories



Sensor/actuator accessories

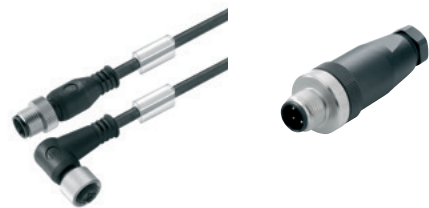

Markers



Protective caps



Ordering data

Description	Type	Qty.	Order No.
DeviceNet™ modules			
16 Digital In	SAI-AU M12 DN 16DI	1	1906700000
16 Digital In / 8 Digital Out	SAI-AU M12 DN 16DI/8DO	1	1906710000
4 Analogue In / 2 Analogue Out / 4 Digital In	SAI-AU M12 DN AI/AO/DI	1	1906720000
16 Digital In	SAI-AU M8 DN 16DI	1	1906730000
16 Digital In / 8 Digital Out	SAI-AU M8 DN 16DI/8DO	1	1906740000

DeviceNet™ accessories

DeviceNet™ cables with female plug and male plug	*)
DeviceNet™ cables with female plug and other side open	*)
DeviceNet™ cables with male plug and other side open	*)

DeviceNet™ plug-in connector

*)

DeviceNet™ terminating resistor

SAIEND CAN-M12 5P A-COD

1

1784760000

Sensor/actuator accessories

Sensor-actuator cables

*)

Sensor-actuator plugs

*)

Markers

Semi-transparent markers for PrintJet printing

ESG 8/13.5/43.3 SAI AU

5

1912130000

Protective caps

M8 Dust cap (Sensor connections)	SAI-SK M8	50	1802760000
M12 Dust cap (Sensor connections)	SAI-SK	30	9456050000
M12 Dust cap (Bus-out and power-out)	SAI-SK-M12-UNI	20	2330260000
M12 Dust cap (Bus-in and power-in)	SAI-SK plug M12	50	1781520000

Note: *) Can be found in our latest catalogue 8, signal and power transmission, order no. 1366750000

SAI Active Universal Pro

IP 67

Professional versions of the Remote I/O System featuring IP 67 protection

B The modules in the SAI Active Universal Pro systems provide additional I/O and functional modules for more versatile topologies. The extension modules come in a compact, space-saving design. They can also be mounted on the side because of the additional drilled holes in the side of the housing. Up to 15 extension modules can be connected over a distance of 50 metres using a shielded, standard M8 sensor cable and the SAI fieldbus module.

In addition to the digital input and output modules, we also offer counter unit modules, thermal modules, RTD modules and analogue modules. The digital input and output modules are also available in M8 and M12 variants. The analogue modules and functional modules are available with M12 connections. Markers are included with every SAI Active module for labelling the I/O channels and the entire device. These markers can be printed on using the PrintJet system from Weidmüller.





Cost-effective Subbus system

Subbus modules are wired up using conventional, shielded, standard M8 sensor cables. Thus there is no need for expensive custom cables. The extension modules enable versatile expansion and minimise the costs associated with the fieldbus interface. The modules do not, however, detract from the performance of the fieldbus system.



Simplified installation

The modules have a compact, space-saving design with additional holes drilled on the side of the housing: this allows them to be installed in a quick and versatile manner. All SAI Active modules with digital inputs or digital outputs are optionally available with standard M8 or M12 connection systems. The outputs are short-circuit-proof and protected against polarity reversal.

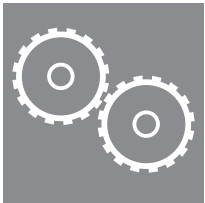

Efficient engineering

All Pro-System modules are described in the standardised fieldbus specific device description files. They can be integrated into any controller unit and corresponding engineering system regardless of the particular manufacturer. The configuration (whether for the input, DESINA input, or output) is carried out without any additional software. Any user can configure directly from the engineering system.

Gateway modules with digital inputs



SAI-AU GW



SAI-AU GW



Ordering data

Module variants	
	16 Digital In
Note	

Type	Qty.	Order No.
SAI-AU M12 PB GW 16DI	1	1938550000

Type	Qty.	Order No.
SAI-AU M8 PB GW 16DI	1	1024310000

Technical data

Connections	
Fieldbus (BUS-IN)	
Fieldbus (BUS-OUT)	
Supply voltage (AUX-IN)	
Connection to Subbus (SUB-OUT)	
I/O connections	
Voltage supply	
Operating voltage	
Contact load	
Max. total current module	
Digital inputs	
Permitted input voltage	
Input current, low	
Input current, high	
Input current, low	
Input current, high	
Input filter	
Fieldbus	
Bus system	
Transmission rate	
Addressing	
System integration	
General data	
L x W x H	
Earth	
Protection degree	
Operating temperature	
Storage temperature	
Housing main material / UL 94 flammability rating	
Certificate	

1x M12 plug 5-pole, B-coded
1x M12 female 5-pole, B-coded
1x M12 plug 5-pole, A-coded
1 x M8 female 4-pole, A-coded
8 x M12 socket 5-pole, A-coded
24 V (18 V DC ... 30 V DC)
Per PIN max. 4 A
8 A
-30 V to +30 V (protected against polarity reversal)
< 15 mA in accordance with EN 61131-2 Type 1
2 mA to 15 mA in accordance with EN 61131-2 Type 1
< 15 mA in accordance with EN 61131-2 Type 1
2 mA to 15 mA in accordance with EN 61131-2 Type 1
1 ms, 3 ms, 5 ms, 10 ms, Configurable
PROFIBUS-DP
Max. 12 Mbit/s (automatic detection)
Via rotary coding switch (1 - 126)
GSD file
210 mm / 54 mm / 32 mm
< 350 g
IP 67
0 °C...+60 °C
-25 °C...+85 °C
Pocan, PBT / V-0
CE, cULus

1x M12 plug 5-pole, B-coded
1x M12 female 5-pole, B-coded
1x M12 plug 5-pole, A-coded
1 x M8 female 4-pole, A-coded
16x M8 female 3-pole
24 V (18 V DC ... 30 V DC)
Per PIN max. 4 A
8 A
-30 V to +30 V (protected against polarity reversal)
< 15 mA in accordance with EN 61131-2 Type 1
2 mA to 15 mA in accordance with EN 61131-2 Type 1
< 15 mA in accordance with EN 61131-2 Type 1
2 mA to 15 mA in accordance with EN 61131-2 Type 1
1 ms, 3 ms, 5 ms, 10 ms, Configurable
PROFIBUS-DP
Max. 12 Mbit/s (automatic detection)
Via rotary coding switch (1 - 126)
GSD file
210 mm / 54 mm / 32 mm
< 350 g
IP 67
0 °C...+60 °C
-25 °C...+85 °C
Pocan, PBT / V-0
CE, cULus

Note

Engineering tables for PROFIBUS



When planning the automation of a facility, you must have a wide variety of components available.

These engineering tables list all the components required for wiring up the SAI Active modules.

PROFIBUS modules



PROFIBUS accessories



Subbus cables / terminating resistor



Sensor/actuator accessories



Markers



Protective caps



Ordering data

Description	Type	Qty.	Order No.
PROFIBUS modules			
PROFIBUS Gateway M12	SAI-AU M12 PB GW 16DI	1	1938550000
PROFIBUS Gateway M8	SAI-AU M8 PB GW 16DI	1	1024310000
Subbus module	SAI-AU M12 SB 8DI	1	1938610000
Subbus module	SAI-AU M12 SB 8DI/8DO	1	1938640000
Subbus module	SAI-AU M8 SB 8DI	1	1938600000
Subbus module	SAI-AU M8 SB 8DI/8DO	1	1938630000
Subbus module	SAI-AU M12 SB AI	1	1938690000
Subbus module	SAI-AU M12 SB AO	1	1938700000
Subbus module	SAI-AU M12 SB PT100	1	1938710000
Subbus module	SAI-AU M12 SB Thermo	1	1938720000
Subbus module	SAI-AU M12 SB Zähler	1	1938730000
Subbus module	SAI-AU M8 SB 8DO 2A	1	1938660000
Subbus module	SAI-AU M12 SB 8DO 2A	1	1938680000
PROFIBUS accessories			
PROFIBUS cables with female plug and male plug			*)
PROFIBUS cables with female plug and other side open			*)
PROFIBUS cables with male plug and other side open			*)
PROFIBUS plug-in connector			*)
PROFIBUS terminating resistor	SAIEND PB M12 4P B-COD	1	1784770000
Subbus cables / terminating resistor			
Subbus cables			*)
Subbus terminating resistor	SAIEND CAN M8 4P	1	1955340000
Sensor/actuator accessories			
Sensor-actuator cables			*)
Sensor-actuator plugs			*)
Markers			
Semi-transparent markers for PrintJet printing	ESG 8/13.5/43.3 SAI AU	5	1912130000
Protective caps			
M8 Dust cap (Sensor connections)	SAI-SK M8	50	1802760000
M12 Dust cap (Sensor connections)	SAI-SK	30	9456050000
M12 Dust cap (Bus-out and power-out)	SAI-SK-M12-UNI	20	2330260000
M12 Dust cap (Bus-in and power-in)	SAI-SK plug M12	50	1781520000

Note: *) Can be found in our latest catalogue 8, signal and power transmission, order no. 1366750000

Gateway modules with digital inputs



SAI-AU GW



Ordering data

Module variants	16 Digital In
Note	

Type	Qty.	Order No.
SAI-AU M12 DN GW 16DI	1	1938570000

Technical data

Connections	
Fieldbus (BUS-IN)	1x M12 plug 5-pole, A-coded
Fieldbus (BUS-OUT)	1x M12 female 5-pole, A-coded
Supply voltage (AUX-IN)	1x M12 plug 5-pole, A-coded
Connection to Subbus (SUB-OUT)	1 x M8 female 4-pole, A-coded
I/O connections	8 x M12 socket 5-pole, A-coded
Voltage supply	
Operating voltage	24 V (18 V DC ... 30 V DC)
Contact load	Per PIN max. 4 A
Max. total current module	8 A
Digital inputs	
Permitted input voltage	-30 V to +30 V (protected against polarity reversal)
Input current, low	< 15 mA in accordance with EN 61131-2 Type 1
Input current, high	2 mA to 15 mA in accordance with EN 61131-2 Type 1
Input current, low	< 15 mA in accordance with EN 61131-2 Type 1
Input current, high	2 mA to 15 mA in accordance with EN 61131-2 Type 1
Input filter	1 ms, 3 ms, 5 ms, 10 ms, Configurable
Fieldbus	
Bus system	DeviceNet™
Transmission rate	Max. 500 kBit/s (automatic detection)
Addressing	Via rotary coding switch (0 - 63)
System integration	EDS file
General data	
L x W x H	210 mm / 54 mm / 32 mm
Earth	< 350 g
Protection degree	IP 67
Operating temperature	0 °C...+60 °C
Storage temperature	-25 °C...+85 °C
Housing main material / UL 94 flammability rating	Pocan, PBT / V-0
Certificate	CE, cULus

Note

Engineering table for DeviceNet™



When planning the automation of a facility, you must have a wide variety of components available.

These engineering tables list all the components required for wiring up the SAI Active modules.

DeviceNet™ modules



DeviceNet™ accessories



Subbus cables / terminating resistor



Sensor/actuator accessories



Markers



Protective caps



Ordering data

Description	Type	Qty.	Order No.
DeviceNet™ modules			
DeviceNet™ Gateway	SAI-AU M12 DN GW 16DI	1	1938570000
Subbus module	SAI-AU M12 SB 8DI	1	1938610000
Subbus module	SAI-AU M12 SB 8DI/8DO	1	1938640000
Subbus module	SAI-AU M8 SB 8DI	1	1938600000
Subbus module	SAI-AU M8 SB 8DI/8DO	1	1938630000
Subbus module	SAI-AU M12 SB AI	1	1938690000
Subbus module	SAI-AU M12 SB AO	1	1938700000
Subbus module	SAI-AU M12 SB PT100	1	1938710000
Subbus module	SAI-AU M12 SB Thermo	1	1938720000
Subbus module	SAI-AU M12 SB Zähler	1	1938730000
Subbus module	SAI-AU M8 SB 8DO 2A	1	1938660000
Subbus module	SAI-AU M12 SB 8DO 2A	1	1938680000

DeviceNet™ accessories

DeviceNet™ cables with female plug and male plug			*)
DeviceNet™ cables with female plug and other side open			*)
DeviceNet™ cables with male plug and other side open			*)

DeviceNet™ plug-in connector			*)
------------------------------	--	--	----

DeviceNet™ terminating resistor	SAIEND CAN-M12 5P A-COD	1	1784760000
---------------------------------	-------------------------	---	------------

Subbus cables / terminating resistor

Subbus cables			*)
---------------	--	--	----

Subbus terminating resistor	SAIEND CAN M8 4P	1	1955340000
-----------------------------	------------------	---	------------

Sensor/actuator accessories

Sensor-actuator cables			*)
------------------------	--	--	----

Sensor-actuator plugs			*)
-----------------------	--	--	----

Markers

Semi-transparent markers for PrintJet printing	ESG 8/13.5/43.3 SAI AU	5	1912130000
--	------------------------	---	------------

Protective caps

M8 Dust cap (Sensor connections)	SAI-SK M8	50	1802760000
M12 Dust cap (Sensor connections)	SAI-SK	30	9456050000
M12 Dust cap (Bus-out and power-out)	SAI-SK-M12-UNI	20	2330260000
M12 Dust cap (Bus-in and power-in)	SAI-SK plug M12	50	1781520000

Note: *) Can be found in our latest catalogue 8, signal and power transmission, order no. 1366750000

Subbus modules with digital inputs/outputs

IP 67

B

SAI-AU Digital



SAI-AU Digital



Ordering data

Module variants
8 Digital In; 8 Digital In / 8 Digital Out
8 Digital In; 8 Digital In / 8 Digital Out
8 Digital Out 2A
8 Digital Out 2A

Note

Technical data

Connections
Supply voltage (AUX-IN)
Connection to Subbus (SUB-IN)
Connection to Subbus (SUB-OUT)
I/O connections
Voltage supply
Operating voltage
Contact load
Max. total current module
Digital inputs
Permitted input voltage
Input current, low
Input current, high
Input current, low
Input current, high
Input filter
Separation of potentials to module electronics
Digital outputs
max. current-carrying capacity per output signal
Separation of potentials to module electronics
Switching frequency, resistive load
Switching frequency, inductive load
Switching frequency, lamp load
Short-circuit-proof
Output voltage, low
Output voltage, high
Max. total current outputs
Fieldbus
Bus system
Addressing
System integration
General data
L x W x H
Earth
Protection degree
Operating temperature
Storage temperature
Housing main material / UL 94 flammability rating
Certificate

Type	Qty.	Order No.
SAI-AU M8 SB 8DI	1	1938600000
SAI-AU M12 SB 8DI	1	1938610000

1 x M8 plug 4-pole, A-coded
1 x M8 female 4-pole, A-coded
4 x M12 female, 5-pole A-coded
24 V (18 V DC ... 30 V DC)
-30 V to +30 V (protected against polarity reversal)
< 15 mA in accordance with EN 61131-2 Type 1
2 mA to 15 mA in accordance with EN 61131-2 Type 1
< 15 mA in accordance with EN 61131-2 Type 1
2 mA to 15 mA in accordance with EN 61131-2 Type 1
1 ms, 3 ms, 5 ms, 10 ms, Configurable
none
Subbus
automatic
automatic
155 mm / 30 mm / 32 mm
< 200 g
IP 67
0 °C...+60 °C
-25 °C...+85 °C
Pocan, PBT / 5VA
CE, cULus

Type	Qty.	Order No.
SAI-AU M8 SB 8DIO	1	1938630000
SAI-AU M12 SB 8DIO	1	1938640000
SAI-AU M8 SB 8DO 2A	1	1938660000
SAI-AU M12 SB 8DO 2A	1	1938680000

1x M12 plug 5-pole, A-coded
1 x M8 plug 4-pole, A-coded
1 x M8 female 4-pole, A-coded
4 x M12 female, 5-pole A-coded
24 V (18 V DC ... 30 V DC)
Per PIN max. 4 A
8 A
-30 V to +30 V (protected against polarity reversal)
< 15 mA in accordance with EN 61131-2 Type 1
2 mA to 15 mA in accordance with EN 61131-2 Type 1
< 15 mA in accordance with EN 61131-2 Type 1
2 mA to 15 mA in accordance with EN 61131-2 Type 1
1 ms, 3 ms, 5 ms, 10 ms, Configurable
none
2 A
none
max. 100 Hz
max. 1 Hz
max. 8 Hz
Yes, cut-off for short circuit and error message
0 V DC
Supply voltage less 0.7 V DC
4 A
Subbus
automatic
automatic
180 mm / 30 mm / 32 mm
< 200 g
IP 67
0 °C...+60 °C
-25 °C...+85 °C
Pocan, PBT / 5VA
CE, cULus

Note

Subbus modules with analogue inputs/outputs

SAI-AU Analog

SAI-AU Analog



Ordering data

Module variants
4 Analogue Out / 4 Analogue In
Note

Type	Qty.	Order No.
SAI-AU M12 SB 4A0	1	1938700000
Note		

Type	Qty.	Order No.
SAI-AU M12 SB 4AI	1	1938690000
Note		

Technical data

Connections
Connection to Subbus (SUB-IN)
Connection to Subbus (SUB-OUT)
I/O connections
Voltage supply
Operating voltage
Analogue inputs
Measurement range
Maximum input voltage in relation to GND
Input resistance (load)
Max. input current (differential)
Short-circuit-proof
Resolution / Accuracy
Analogue outputs
Measurement range
Output interval
Short-circuit-proof
Resolution / Accuracy
Fieldbus
Bus system
Addressing
System integration
General data
L x W x H
Earth
Protection degree
Operating temperature
Storage temperature
Housing main material / UL 94 flammability rating
Certificate

1 x M8 plug 4-pole, A-coded
1 x M8 female 4-pole, A-coded
4 x M12 female, 5-pole A-coded
24 V (18 V DC ... 30 V DC)
-10 V ... +10 V, 0 V ... 10 V, 0 ... 20 mA, 4...20 mA
5 ms to 250 ms (can be configured)
Yes
12-bit / < 0.2 %
Subbus
automatic
automatic
155 mm / 30 mm / 32 mm
< 200 g
IP 67
0 °C...+60 °C
-25 °C...+85 °C
Pocan, PBT / 5VA
CE, cULus

1 x M8 plug 4-pole, A-coded
1 x M8 female 4-pole, A-coded
4 x M12 female, 5-pole A-coded
24 V (18 V DC ... 30 V DC)
-10 V ... +10 V, 0 V ... 10 V, 0 ... 20 mA, 4...20 mA
35 V
<125 Ohm
-50 mA to +50 mA (protected against polarity reversal)
Yes
12-bit / < 0.2 %
Subbus
automatic
automatic
155 mm / 30 mm / 32 mm
< 200 g
IP 67
0 °C...+60 °C
-25 °C...+85 °C
Pocan, PBT / 5VA
CE, cULus

Note

Note

Note

Subbus modules with functional inputs

SAI-AU Counter



Ordering data

Module variants
2 counter inputs / 2 gate outputs
Note

Type	Qty.	Order No.
SAI-AU M12 SB 2Counter	1	1938730000

Technical data

Connections	
Supply voltage (AUX-IN)	1 x M12 plug 5-pole, A-coded
Connection to Subbus (SUB-IN)	1 x M8 plug 4-pole, A-coded
Connection to Subbus (SUB-OUT)	1 x M8 female 4-pole, A-coded
I/O connections	4 x M12 female, 5-pole A-coded
Voltage supply	
Operating voltage	24 V (18 V DC ... 30 V DC)
Contact load	Per PIN max. 4 A
Max. total current module	8 A
Functional inputs	
Counting breadth	32 Bit
Switching frequency	100 kHz
Number of inputs	2 x enables, 2 x counters, 2 x count directions
Fieldbus	
Bus system	Subbus
Addressing	automatic
System integration	automatic
General data	
L x W x H	180 mm / 30 mm / 32 mm
Earth	< 200 g
Protection degree	IP 67
Operating temperature	0 °C...+60 °C
Storage temperature	-25 °C...+85 °C
Housing main material / UL 94 flammability rating	Pocan, PBT / 5VA
Certificate	CE, cULus

Note

Subbus modules with functional inputs

SAI-AU Thermo



Ordering data

Module variants	4 thermal inputs
Note	

Type	Qty.	Order No.
SAI-AU M12 SB 4Thermo	1	1938720000

Technical data

Connections	1 x M8 plug 4-pole, A-coded 1 x M8 female 4-pole, A-coded 4 x M12 female, 5-pole A-coded
Connection to Subbus (SUB-IN)	
Connection to Subbus (SUB-OUT)	
I/O connections	
Voltage supply	24 V (18 V DC ... 30 V DC)
Operating voltage	
Functional inputs	Types J, K, L, B, E, N, R, S, T, U: mV readings Typical for sensor, Preset Type K, -100 °C to 1,370 °C 0.1 °C per digit 250 ms (can be configured to 70 ms) < ± 0.5 % (of measuring range limit)
Sensor	
Temperature range	
Resolution	
Conversion time	
Measurement error	
Input filter	Configurable
cold junction compensation	External PT1000 connection on pins 1 and 3 (GND)
Fieldbus	Subbus automatic automatic
Bus system	
Addressing	
System integration	
General data	155 mm / 30 mm 32 mm < 200 g IP 67 0 °C...+60 °C -25 °C...+85 °C Pocan, PBT / 5VA CE, cULus
L x W x H	
Earth	
Protection degree	
Operating temperature	
Storage temperature	
Housing main material / UL 94 flammability rating	
Certificate	

Note

Subbus modules with functional inputs

SAI-AU PT100



Ordering data

Module variants	4 PT100 inputs
Note	

Type	Qty.	Order No.
SAI-AU M12 SB 4PT100	1	1938710000

Technical data

Connections	1 x M8 plug 4-pole, A-coded 1 x M8 female 4-pole, A-coded 4 x M12 female, 5-pole A-coded
Connection to Subbus (SUB-IN)	
Connection to Subbus (SUB-OUT)	
I/O connections	
Voltage supply	24 V (18 V DC ... 30 V DC)
Operating voltage	
Functional inputs	N100, N1000, N120, PT100, PT1000, PT200, PT300, PT500, Potentiometer connection, Resistance measurement
Sensor	0.1 °C per digit
Resolution	250 ms (can be configured to 65 ms)
Conversion time	< ± 1 °C
Measurement error	Configurable
Input filter	-200 °C ... + 850 °C
Measurement range for PT sensors	-60 °C ... +250 °C
Measurement range for Ni sensors	max. 4000 Ohm
Resistance measurement	100 to 4000 Ω (three-wire connection)
Potentiometer	Typically 0.5 mA
Measurement current	
Fieldbus	Subbus
Bus system	automatic
Addressing	automatic
System integration	
General data	155 mm / 30 mm / 32 mm
L x W x H	< 200 g
Earth	IP 67
Protection degree	0 °C...+60 °C
Operating temperature	-25 °C...+85 °C
Storage temperature	Pocan, PBT / 5VA
Housing main material / UL 94 flammability rating	CE, cULus
Certificate	

Note	
-------------	--

--	--

Sensor Cables u-remote

Weidmüller is also offering the required sensor and actuator cables as a supplement to the new, innovative u-remote system. Generally, there are two different courses of action for cabling.

- Circular plug cables assembled on one end
- Cables assembled on both ends with u-remote plug-in connectors already connected

To make things easier to understand, only the M8 and M12 cables have been shown in this diagram. Actuator cables can also be found in catalogue 8.

The PUR cable used here is black, halogen-free and suitable for dragline cable carriers. The PVC cable is suitable for dragline cable carriers. Further technical details are available in catalogue 8.

The minimum order quantity for each type of cable is 1 unit. This means that sample parts and the demand for replacement parts are also easy to manage.

Standard cable lengths

The cable lengths listed under order data are all 1.5 m. To order any other standard cable lengths, simply change the last four numbers in the order number. Additional lengths can be supplied at the request of the customer.

Order data

Type	Length	Order No.
	1.5 m	xxxxxx0150
	3.0 m	xxxxxx0300
	5.0 m	xxxxxx0500
	10.0 m	xxxxxx1000

Description code example

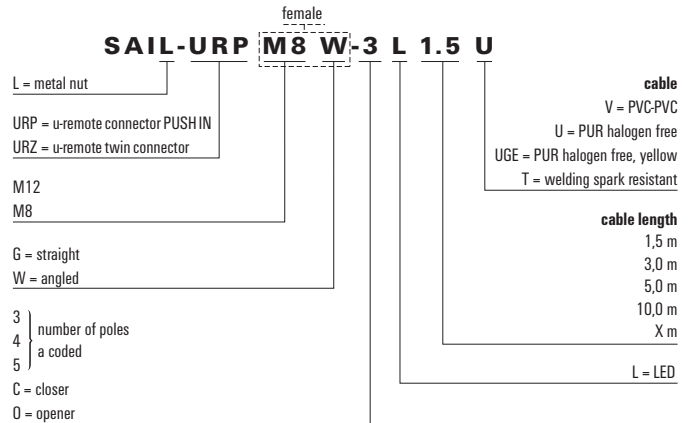

Connecting cables

u-remote plug / M12
u-remote plug / M8



Technical data

Rated current
Rated voltage (in accordance with VDE standard 0110 ISO group C)
Temperature range of housing
Core cross-section
Type of protection
Contact surface
Sheath material
Wire core insulation

Halogen-free PUR

4 A
M12: 250 V / M8: 60 V (3-pole) / LED: 24 V
-25 to +85 °C
M12: 0.34 mm ² / M8: 0.25 mm ²
IP 67/68 (M12/M8 head)
Gold-plated
PUR
TPM

PVC

4 A
M12: 250 V / M8: 60 V (3-pole) / LED: 24 V
-25 to +85 °C
M12: 0.34 mm ² / M8: 0.25 mm ²
IP 67/68 (M12/M8 head)
Gold-plated
PVC
PVC

Order data

Module variants

NO contact / u-remote plug - M12 straight socket
NO contact / u-remote plug - M12 angled socket
NC contact / u-remote plug - M12 straight socket
NC contact / u-remote plug - M12 angled socket
4-pin / u-remote plug - M12 straight socket
4-pin / u-remote plug - M12 angled socket
3-pin / u-remote plug - M8 straight socket
3-pin / u-remote plug - M8 angled socket
4-pin / u-remote plug - M12 angled socket - LED
3-pin / u-remote plug - M8 angled socket - LED
Twin / NO contact / u-remote plug - M12 straight socket
Twin / NO contact / u-remote plug - M12 angled socket
Twin / 3-pin / u-remote plug - M8 straight socket
Twin / 3-pin / u-remote plug - M8 angled socket

Type	Qty.	Order No.
SAIL-URPM12G-C-1.5U	1	1475070150
SAIL-URPM12W-C-1.5U	1	1475080150
SAIL-URPM12G-O-1.5U	1	1475090150
SAIL-URPM12W-O-1.5U	1	1475120150
SAIL-URPM12G-4-1.5U	1	1475130150
SAIL-URPM12W-4-1.5U	1	1475140150
SAIL-URPM8G-3-1.5U	1	1475160150
SAIL-URPM8W-3-1.5U	1	1475170150
SAIL-URPM12W-2L-1.5U	1	1475450150
SAIL-URPM8W-2L-1.5U	1	1475470150
SAIL-URZM12G-C-1.5U	1	1475030150
SAIL-URZM12W-C-1.5U	1	1475040150
SAIL-URZM8G-3-1.5U	1	1475050150
SAIL-URZM8W-3-1.5U	1	1475060150

Type	Qty.	Order No.
SAIL-URPM12G-C-1.5V	1	1475280000
SAIL-URPM12W-C-1.5V	1	1475290000
SAIL-URPM12G-O-1.5V	1	1475300000
SAIL-URPM12W-O-1.5V	1	1475310000
SAIL-URPM12G-4-1.5V	1	1475320000
SAIL-URPM12W-4-1.5V	1	1475330000
SAIL-URPM8G-3-1.5V	1	1475340000
SAIL-URPM8W-3-1.5V	1	1475350000
SAIL-URPM12W-2L-1.5V	1	1475500150
SAIL-URPM8W-2L-1.5V	1	1475510150

Accessories

M8/M12 cable gland tool torque

Type	Qty.	Order No.
Screwty®-Set-DM	1	1920000000

Type	Qty.	Order No.
Screwty®-Set-DM	1	1920000000

Wiring diagram

3-pin / NO contact

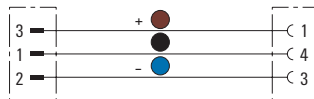

NC contact

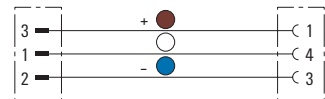

4-pin

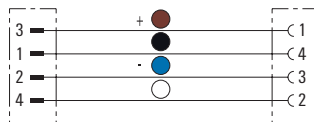

Twin / NO contact

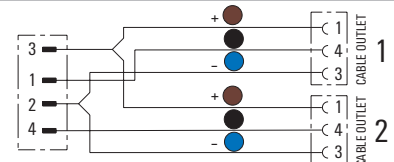

M12 cables with connector at one end only

3-pin

4-pin

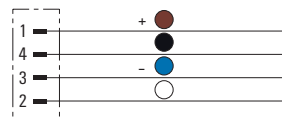
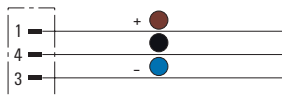

Technical data

Rated current
Rated voltage (in accordance with VDE standard 0110 ISO group C)
Temperature range of housing
Core cross-section
Type of protection
Contact surface
Sheath material
Wire core insulation

4 A
250 V
-25 to +85 °C
0.34 mm ²
IP 67/68
Gold-plated
PUR
PUR

4 A
250 V
-25 to +85 °C
0.34 mm ²
IP 67/68
Gold-plated
PVC
PVC

Order data

Module variants
PVC M12 straight socket
Halogen-free PUR M12 straight socket
Yellow halogen-free PUR M12 straight socket
Halogen-free PUR M12 straight socket, resistant to welding beads
PVC M12 angled socket
Halogen-free PUR M12 angled socket
Yellow halogen-free PUR M12 angled socket
Halogen-free PUR M12 angled socket, resistant to welding beads

Type	Qty.	Order No.
SAIL-M12BG-3-1.5V	1	1925570150
SAIL-M12BG-3-1.5U	1	9457820150
SAIL-M12BG-3-1.5UGE	1	1092910150
SAIL-M12BG-3-1.5T	1	1968590150
SAIL-M12BW-3-1.5V	1	1925630150
SAIL-M12BW-3-1.5U	1	9457320150
SAIL-M12BW-3-1.5UGE	1	1092940150
SAIL-M12BW-3-1.5T	1	1968560150

Type	Qty.	Order No.
SAIL-M12BG-4-1.5V	1	1925580150
SAIL-M12BG-4-1.5U	1	9457730150
SAIL-M12BG-4-1.5UGE	1	1092920150
SAIL-M12BG-4-1.5T	1	1968580150
SAIL-M12BW-4-1.5V	1	1925640150
SAIL-M12BW-4-1.5U	1	9457740150
SAIL-M12BW-4-1.5UGE	1	1092960150
SAIL-M12BW-4-1.5T	1	1968570150

Accessories

M8/M12 cable gland tool torque

Type	Qty.	Order No.
Screwty [®] -Set-DM	1	1920000000

Type	Qty.	Order No.
Screwty [®] -Set-DM	1	1920000000

M8 cables with connector at one end only

3-pin

4-pin

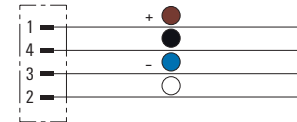
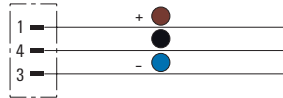

Technical data

Rated current
Rated voltage (in accordance with VDE standard 0110 ISO group C)
Temperature range of housing
Core cross-section
Type of protection
Contact surface
Sheath material
Wire core insulation

4 A
60 V
-25 to +85 °C
0.25 mm ²
IP 67/68
Gold-plated
PUR
PUR

4 A
30 V
-25 to +85 °C
0.25 mm ²
IP 67/68
Gold-plated
PVC
PVC

Ordering data

Module variants
PVC M8 straight socket
Halogen-free PUR M8 straight socket
Yellow halogen-free PUR M8 straight socket
PVC M8 angled socket
Halogen-free PUR M8 angled socket
Yellow halogen-free PUR M8 angled socket

Type	Qty.	Order No.
SAIL-M8BG-3-1.5V	1	1927240150
SAIL-M8BG-3-1.5U	1	9457450150
SAIL-M8BG-3-1.5UGE	1	1093190150
SAIL-M8BW-3-1.5V	1	1927320150
SAIL-M8BW-3-1.5U	1	9457380150
SAIL-M8BW-3-1.5UGE	1	1093220150

Type	Qty.	Order No.
SAIL-M8BG-4-1.5V	1	1927260150
SAIL-M8BG-4-1.5U	1	9457850150
SAIL-M8BG-4-1.5UGE	1	1093200150
SAIL-M8BW-4-1.5V	1	1927340150
SAIL-M8BW-4-1.5U	1	9456150150
SAIL-M8BW-4-1.5UGE	1	1093240150

Accessories

M8/M12 cable gland tool torque

Type	Qty.	Order No.
Screwty®-Set-DM	1	1920000000

Type	Qty.	Order No.
Screwty®-Set-DM	1	1920000000

M12/M8 cables with connector at one end only
With LED

3-pin / 2 LEDs

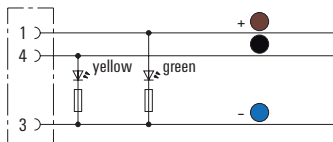

4-pin / 2 LEDs

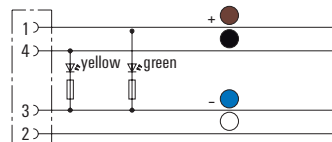

Technical data

Rated current
Rated voltage (in accordance with VDE standard 0110 ISO group C)
Temperature range of housing
Core cross-section
Type of protection
Contact surface
Sheath material
Wire core insulation

4 A
24 V
-25 to +85 °C
M12: 0.34 mm ² / M8: 0.25 mm ²
IP 67/68
Gold-plated
PUR
PUR

4 A
24 V
-25 to +85 °C
M12: 0.34 mm ² / M8: 0.25 mm ²
IP 67/68
Gold-plated
PUR
PUR

Order data

Module variants
PVC M12 angled socket
Halogen-free PUR M12 angled socket
Yellow halogen-free PUR M12 angled socket
Halogen-free PUR M12 angled socket, resistant to welding beads
PVC M8 angled socket
Halogen-free PUR M8 angled socket
Yellow halogen-free PUR M8 angled socket

Type	Qty.	Order No.
SAIL-M12BW-3L1.5V		1925460150
SAIL-M12BW-3L1.5U		9457800150
SAIL-M12BW-3L1.5UGE		1114880150
SAIL-M12BW-3L1.5T		1004330150
SAIL-M8BW-3L1.5V		1927350150
SAIL-M8BW-3L1.5U		9457460150
SAIL-M8BW-3L1.5UGE		1093210150

Type	Qty.	Order No.
SAIL-M12BW-4-2L1.5V		1925470150
SAIL-M12BW-4-2L1.5U		9456380150
SAIL-M12BW-4-2L1.5UGE		1092950150
SAIL-M12BW-4-2L1.5T		1007000150
SAIL-M8BW-4L1.5V		1927360150
SAIL-M8BW-4L1.5U		1906400150
SAIL-M8BW-4L1.5UGE		1093230150

Accessories

M8/M12 cable gland tool torque

Type	Qty.	Order No.
Screwty®-Set-DM	1	1920000000

Type	Qty.	Order No.
Screwty®-Set-DM	1	1920000000

M12 straight/angled socket

Dimensioned drawing

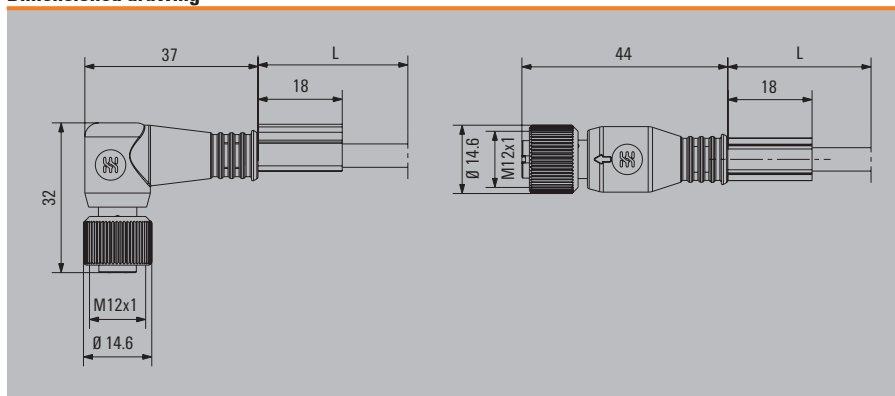

M8 straight/angled socket

Dimensioned drawing

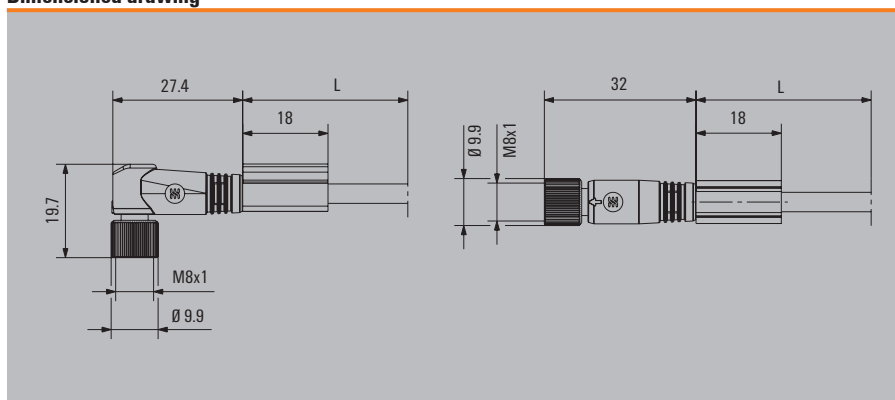

Screwty® set-DM

Contents:

- 1x interchangeable bit
- 1x torque handle
- 1x adjustment aid for Screwty® torque (M8: 0.5 - 0.6 Nm / M12: 0.8 - 1.2 Nm) ← hier ok?
- 1x Screwty® M12, M8, M12 F, M8 F attachment



Ordering data

Type	Qty.	Order No.
Screwty®-Set-DM	1	1920000000



Index

Index	Index Type	X.2
	Index Order No.	X.3
	Addresses worldwide	X.4

Type	Order No.	Page
------	-----------	------

D

DEK 5/8-11.5 MC NE WS	1341630000	A.69
DEK 5/8-11.5 MC SDR	1341610000	A.69

E

ESG 8/13.5/43.3 SAI AU	1912130000	B.12
ESO UR20 DIN A4 WS	1429430000	A.69

K

KOSM BHZ5.00	1483050000	A.69
--------------	------------	------

M

multi-stripax 6-16	9202210000	A.20
--------------------	------------	------

P

PM 2.7/2.6 MC NE WS	1323710000	A.69
PM 2.7/2.6 MC SDR	1323700000	A.69
PWZ RJ54	1118040000	A.20

S

SAI-AU M12 CAN 16DI	1906650000	B.14
SAI-AU M12 CAN 16DI/8DO	1906660000	B.14
SAI-AU M12 CAN AI/AO/DI	1906670000	B.15
SAI-AU M12 DN 16DI	1906700000	B.18
SAI-AU M12 DN 16DI/8DO	1906710000	B.18
SAI-AU M12 DN AI/AO/DI	1906720000	B.19
SAI-AU M12 DN GW 16DI	1938570000	B.26
SAI-AU M12 PB 16DI	1890020000	B.10
SAI-AU M12 PB 16DI/8DO	1890010000	B.10
SAI-AU M12 PB 8DI/8DO 2A	1968220000	B.10
SAI-AU M12 PB AI/AO/DI	1890000000	B.11
SAI-AU M12 PB GW 16DI	1938550000	B.24
SAI-AU M12 SB 2Counter	1938730000	B.30
SAI-AU M12 SB 4AI	1938690000	B.29
SAI-AU M12 SB 4AO	1938700000	B.29
SAI-AU M12 SB 4PT100	1938710000	B.32
SAI-AU M12 SB 4Thermo	1938720000	B.31
SAI-AU M12 SB 8DI	1938610000	B.28
SAI-AU M12 SB 8DI0	1938640000	B.28
SAI-AU M12 SB 8DO 2A	1938680000	B.28
SAI-AU M8 CAN 16DI	1906680000	B.14
SAI-AU M8 CAN 16DI/8DO	1906690000	B.14
SAI-AU M8 DN 16DI	1906730000	B.18
SAI-AU M8 DN 16DI/8DO	1906740000	B.18
SAI-AU M8 PB 16DI	1906550000	B.10
SAI-AU M8 PB 16DI/8DO	1906640000	B.10
SAI-AU M8 PB 8DI/8DO 2A	1975450000	B.10
SAI-AU M8 PB GW 16DI	1024310000	B.24
SAI-AU M8 SB 8DI	1938600000	B.28
SAI-AU M8 SB 8DI0	1938630000	B.28
SAI-AU M8 SB 8DO 2A	1938660000	B.28
SAI-SK	9456050000	B.12
SAI-SK M8	1802780000	B.12
SAI-SK Stecker M12	1781520000	B.12
SAI-SK-M12-UNI	2320360000	B.12
SAIEND CAN M8 4P	1955340000	B.25
SAIEND CAN-M12 5P A-COD	1784760000	B.16
SAIEND PB M12 4P B-COD	1784770000	B.12
SAIL-M12BG-3-1.5T	1968590150	B.36
SAIL-M12BG-3-1.5U	9457820150	B.36
SAIL-M12BG-3-1.5UGE	1092910150	B.36
SAIL-M12BG-3-1.5V	1925570150	B.36
SAIL-M12BG-4-1.5T	1968580150	B.36
SAIL-M12BG-4-1.5U	945730150	B.36
SAIL-M12BG-4-1.5UGE	1092920150	B.36
SAIL-M12BG-4-1.5V	1925580150	B.36
SAIL-M12BW-3-1.5T	1968560150	B.36
SAIL-M12BW-3-1.5U	9457320150	B.36
SAIL-M12BW-3-1.5UGE	1092940150	B.36
SAIL-M12BW-3-1.5V	1925630150	B.36
SAIL-M12BW-3L1.5T	1004330150	B.38
SAIL-M12BW-3L1.5U	9457800150	B.38
SAIL-M12BW-3L1.5UGE	1114880150	B.38
SAIL-M12BW-3L1.5V	1925460150	B.38
SAIL-M12BW-4-1.5T	1968570150	B.36
SAIL-M12BW-4-1.5U	945740150	B.36
SAIL-M12BW-4-1.5UGE	1092960150	B.36
SAIL-M12BW-4-1.5V	1925640150	B.36
SAIL-M12BW-4-2L1.5T	1007000150	B.38
SAIL-M12BW-4-2L1.5U	9456380150	B.38
SAIL-M12BW-4-2L1.5UGE	1092950150	B.38
SAIL-M12BW-4-2L1.5V	1925470150	B.38
SAIL-M8BG-3-1.5U	9457450150	B.37
SAIL-M8BG-3-1.5UGE	1093190150	B.37
SAIL-M8BG-3-1.5V	1927240150	B.37
SAIL-M8BG-4-1.5U	9457850150	B.37
SAIL-M8BG-4-1.5UGE	1093200150	B.37
SAIL-M8BG-4-1.5V	1927260150	B.37
SAIL-M8BW-3-1.5U	9457380150	B.37
SAIL-M8BW-3-1.5UGE	1093220150	B.37
SAIL-M8BW-3-1.5V	1927320150	B.37
SAIL-M8BW-3L1.5U	9457460150	B.38
SAIL-M8BW-3L1.5UGE	1093210150	B.38

Type	Order No.	Page
------	-----------	------

SAIL-M8BW-3L1.5V	1927350150	B.38
SAIL-M8BW-4-1.5U	9456150150	B.37
SAIL-M8BW-4-1.5UGE	1093240150	B.37
SAIL-M8BW-4-1.5V	1927340150	B.37
SAIL-M8BW-4L1.5U	1906400150	B.38
SAIL-M8BW-4L1.5UGE	1093230150	B.38
SAIL-M8BW-4L1.5V	1927360150	B.38
SAIL-URPM12G-4-1.5U	1475130150	B.35
SAIL-URPM12G-4-1.5V	1475320000	B.35
SAIL-URPM12G-C-1.5U	1475070150	B.35
SAIL-URPM12G-C-1.5V	1475280000	B.35
SAIL-URPM12G-O-1.5U	1475090150	B.35
SAIL-URPM12G-O-1.5V	1475300000	B.35
SAIL-URPM12W-2L-1.5U	1475450150	B.35
SAIL-URPM12W-2L-1.5V	1475500150	B.35
SAIL-URPM12W-4-1.5U	1475140150	B.35
SAIL-URPM12W-4-1.5V	1475330000	B.35
SAIL-URPM12W-C-1.5U	1475080150	B.35
SAIL-URPM12W-C-1.5V	1475290000	B.35
SAIL-URPM12W-O-1.5U	1475120150	B.35
SAIL-URPM12W-O-1.5V	1475310000	B.35
SAIL-URPM8G-3-1.5U	1475160150	B.35
SAIL-URPM8G-3-1.5V	1475340000	B.35
SAIL-URPM8W-2L-1.5U	1475470150	B.35
SAIL-URPM8W-2L-1.5V	1475510150	B.35
SAIL-URPM8W-3-1.5U	1475170150	B.35
SAIL-URPM8W-3-1.5V	1475350000	B.35
SAIL-URZM12G-C-1.5U	1475030150	B.35
SAIL-URZM12W-C-1.5U	1475040150	B.35
SAIL-URZM8G-3-1.5U	1475050150	B.35
SAIL-URZM8W-3-1.5U	1475060150	B.35
Screwty®-Set-DM	1920000000	B.35

T

THM UR20 GE	1429910000	A.69
THM UR20 WS	1429420000	A.69

U

UR20-16AUX-FE	1334790000	A.69
UR20-16AUX-GND-I	1334800000	A.69
UR20-16AUX-GND-O	1334810000	A.69
UR20-16AUX-I	1334770000	A.69
UR20-16AUX-O	1334780000	A.69
UR20-16DI-P	1315200000	A.21
UR20-16DI-P-PLC-INT	1315210000	A.22
UR20-16DO-P	1315250000	A.31
UR20-16DO-P-PLC-INT	1315270000	A.32
UR20-1CNT-100-100	1315570000	A.37
UR20-2CNT-100	1315590000	A.38
UR20-2DI-P-TS	1460140000	A.23
UR20-2FNT-100	1508080000	A.39
UR20-2PWM-PN-0.5A	1315600000	A.41
UR20-2PWM-PN-2A	1315610000	A.42
UR20-4AI-RTD-DIAG	1315700000	A.54
UR20-4AI-TC-DIAG	1315710000	A.53
UR20-4AI-UJ-12	1394390000	A.49
UR20-4AI-UJ-16	1315620000	A.45
UR20-4AI-UJ-16-DIAG	1315690000	A.46
UR20-4AI-UJ-16-DIAG-HD	1506910000	A.48
UR20-4AI-UJ-16-HD	1506920000	A.47
UR20-4AO-UJ-16	1315680000	A.57
UR20-4AO-UJ-16-DIAG	1315730000	A.58
UR20-4DI-P	1315170000	A.17
UR20-4DI-P-TS	1460150000	A.24
UR20-4DO-P	1315220000	A.27
UR20-4DO-P-2A	1315230000	A.28
UR20-4DO-PN-2A	1394420000	A.29
UR20-4RO-CD-255	1315550000	A.34
UR20-4RO-SSR-255	1315540000	A.33
UR20-8AI-PLC-ANT	1315670000	A.50
UR20-8DI-P-2W	1315180000	A.18
UR20-8DI-P-3W	1394400000	A.19
UR20-8DI-P-3W-HD	1315190000	A.20
UR20-8DO-P	1315240000	A.30
UR20-BM-PFI-SP	1350940000	A.71
UR20-BM-PFI-O-SP	1350950000	A.71
UR20-BM-SIL-SP	1350970000	A.71
UR20-BM-SP	1350930000	A.71
UR20-EBK-ACC	1346610000	A.69
UR20-EM-1315080000-SP	1346650000	A.71
UR20-EM-1315170000-SP	1346640000	A.71
UR20-EM-1315190000-SP	1346670000	A.71
UR20-EM-1315200000-SP	1346680000	A.71
UR20-EM-1315210000-SP	1346690000	A.71
UR20-EM-1315220000-SP	1346700000	A.71
UR20-EM-1315230000-SP	1346710000	A.71
UR20-EM-1315240000-SP	1346720000	A.71
UR20-EM-1315250000-SP	1346730000	A.71
UR20-EM-1315270000-SP	1346740000	A.71
UR20-EM-1315540000-SP	1347120000	A.71
UR20-EM-1315550000-SP	1347130000	A.71
UR20-EM-1315570000-SP	1347140000	A.71
UR20-EM-1315590000-SP	1347150000	A.71
UR20-EM-1315600000-SP	1347180000	A.71
UR20-EM-1315610000-SP	1347190000	A.71
UR20-EM-1315620000-SP	1347200000	A.71
UR20-EM-1315670000-SP	1347250000	A.71
UR20-EM-1315680000-SP	1347270000	A.71
UR20-EM-1315690000-SP	1347280000	A.71
UR20-EM-1315700000-SP	1347290000	A.71
UR20-EM-1315710000-SP	1435740000	A.71
UR20-EM-1315730000-SP	1347330000	A.71
UR20-EM-1315770000-SP	1347370000	A.71
UR20-EM-1334710000-SP	1347370000	A.71
UR20-EM-1334740000-SP	1347420000	A.71
UR20-EM-1334770000-SP	1347450000	A.71
UR20-EM-1334780000-SP	1347470000	A.71
UR20-EM-1334790000-SP	1347480000	A.71
UR20-EM-1334800000-SP	1347490000	A.71
UR20-EM-1334810000-SP	1347500000	A.71
UR20-EM-1335030000-SP	1347520000	A.71
UR20-EM-1335040000-SP	1347530000	A.71
UR20-EM-1335050000-SP	1347540000	A.71
UR20-EM-1394390000-SP	1434230000	A.71
UR20-EM-1394400000-SP	1434220000	A.71
UR20-EM-1394420000-SP	1480950000	A.71
UR20-EM-1460140000-SP	1463690000	A.71
UR20-EM-1460150000-SP	1463680000	A.71
UR20-EM-1506910000-SP	1515430000	A.71
UR20-EM-1506920000-SP	1515420000	A.71
UR20-EM-1508080000-SP	1515440000	A.71
UR20-ES	1315770000	A.70
UR20-FBCEC	1334910000	A.13
UR20-FBC-MOD-TCP	1334930000	A.15
UR20-FBC-PB-PP	1334870000	A.9
UR20-FBC-PN-IRT	1334880000	A.11
UR20-PFI	1334710000	A.61
UR20-PFI-O	1334740000	A.62
UR20-PFI-O-1DI-SIL	1335030000	A.65
UR20-PFI-O-2DI-DELAY-SIL	1335040000	A.67
UR20-PFI-O-2DI-SIL	1335050000	A.66
UR20-PG0.35	1469340000	A.20
UR20-PK-1315170000-SP	1346440000	A.71
UR20-PK-1315180000-SP	1346430000	A.71
UR20-PK-1315190000-SP	1518800000	A.71
UR20-PK-1315200000-SP	1346400000	A.71
UR20-PK-1315210000-SP	1346590000	A.71
UR20-PK-1315220000-SP	1483960000	A.71
UR20-PK-1315230000-SP	1483970000	A.71
UR20-PK-1315240000-SP	1346410000	A.71
UR20-PK-1315250000-SP	1483990000	A.71
UR20-PK-1315270000-SP	1483940000	A.71
UR20-PK-1315540000-SP	1484000000	A.71
UR20-PK-1315550000-SP	1346500000	A.71
UR20-PK-1315570000-SP	1346520000	A.71
UR20-PK-1315590000-SP	1346540000	A.71
UR20-PK-1315600000-SP	1484010000	A.71
UR20-PK-1315610000-SP	1346550000	A.71
UR20-PK-1315670000-SP	1484020000	A.71
UR20-PK-1315680000-SP	1483950000	A.71
UR20-PK-1315690000-SP	1484070000	A.71
UR20-PK-1315700000-SP	1518870000	A.71
UR20-PK-1315710000-SP	1484040000	A.71
UR20-PK-1315730000-SP	1484050000	A.71
UR20-PK-1315770000-SP	1518880000	A.71
UR20-PK-1315790000-SP	1346510000	A.71
UR20-PK-1334710000-SP	1346460000	A.71
UR20-PK-1334740000-SP	1346480000	A.71
UR20-PK-1334770000-SP	1346450000	A.71
UR20-PK-1334780000-SP	1484080000	A.71
UR20-PK-1334790000-SP	1346490000	A.71
UR20-PK-1334800000-SP	1346470000	A.71
UR20-PK-1334810000-SP	1484090000	A.71
UR20-PK-1334870000-SP	1361520000	A.71
UR20-PK-1334880000-SP	1484120000	A.71
UR20-PK-1334910000-SP	1484440000	A.71
UR20-PK-1334930000-SP	1484130000	A.71
UR20-PK-1335030000-SP	1346560000	A.71
UR20-PK-1335		

Order No.	Type	Page
-----------	------	------

100000000

1004330150	SAIL-M12BW-3L1.5T	B.38
1007000150	SAIL-M12BW-4.2L1.5T	B.38

102000000

1024310000	SAI-AU M8 PB GW 16DI	B.24
------------	----------------------	------

109000000

1092910150	SAIL-M12BG-3-1.5UGE	B.36
1092920150	SAIL-M12BG-4-1.5UGE	B.36
1092940150	SAIL-M12BW-3-1.5UGE	B.36
1092950150	SAIL-M12BW-4.2L1.5UGE	B.38
1092960150	SAIL-M12BW-4-1.5UGE	B.36
1093190150	SAIL-M8BG-3-1.5UGE	B.37
1093200150	SAIL-M8BG-4-1.5UGE	B.37
1093210150	SAIL-M8BW-3L1.5UGE	B.38
1093220150	SAIL-M8BW-3L1.5UGE	B.37
1093230150	SAIL-M8BW-4L1.5UGE	B.38
1093240150	SAIL-M8BW-4-1.5UGE	B.37

111000000

1114880150	SAIL-M12BW-3L1.5UGE	B.38
1118040000	PWZ RJ54	A.20

131000000

1315170000	UR20-4DLP	A.17
1315180000	UR20-8DI-P-2W	A.18
1315190000	UR20-8DI-P-3W-HD	A.20
1315200000	UR20-16DIP	A.21
1315210000	UR20-16DI-P-PLC-INT	A.22
1315220000	UR20-4DD-P	A.27
1315230000	UR20-4DD-P-2A	A.28
1315240000	UR20-8DD-P	A.30
1315250000	UR20-16DD-P	A.31
1315270000	UR20-16DD-P-PLC-INT	A.32
1315540000	UR20-4RO-SSR-255	A.33
1315550000	UR20-4RO-CD-255	A.34
1315570000	UR20-1CNT-100-1DD	A.37
1315590000	UR20-2CNT-100	A.38
1315600000	UR20-2PWM-PN-0.5A	A.41
1315610000	UR20-2PWM-PN-2A	A.42
1315620000	UR20-4AIUI-16	A.45
1315670000	UR20-8AIH-PLC-INT	A.50
1315680000	UR20-4AG-UI-16	A.57
1315690000	UR20-4AI-UI-16-DIAG	A.46
1315700000	UR20-4AI-RTD-DIAG	A.54
1315710000	UR20-4AI-TC-DIAG	A.53
1315730000	UR20-4AO-UI-16-DIAG	A.58
1315770000	UR20-ES	A.70

132000000

1323700000	PM 2.7/2.6 MC SDR	A.69
1323710000	PM 2.7/2.6 MC NE WS	A.69

133000000

1334710000	UR20-PF-I	A.61
1334740000	UR20-PF-O	A.62
1334770000	UR20-16AUX-I	A.69
1334780000	UR20-16AUX-O	A.69
1334790000	UR20-16AUX-FE	A.69
1334800000	UR20-16AUX-GND-I	A.69
1334810000	UR20-16AUX-GND-O	A.69
1334870000	UR20-FBC-PB-DP	A.9
1334880000	UR20-FBC-PN-IRT	A.11
1334910000	UR20-FBC-EC	A.13
1334930000	UR20-FBC-MOD-TCP	A.15
1335030000	UR20-PF-O-1DI-SIL	A.65
1335040000	UR20-PF-O-2DI-DELAY-SIL	A.67
1335050000	UR20-PF-O-2DI-SIL	A.66
1339920000	UR20-SM-ACC	A.69

134000000

1341610000	DEK 5/8-11.5 MC SDR	A.69
1341630000	DEK 5/8-11.5 MC NE WS	A.69
1346400000	UR20-PK-1315200000-SP	A.71
1346410000	UR20-PK-1315240000-SP	A.71
1346430000	UR20-PK-1315180000-SP	A.71
1346440000	UR20-PK-1315170000-SP	A.71
1346450000	UR20-PK-1334770000-SP	A.71
1346460000	UR20-PK-1334710000-SP	A.71
1346470000	UR20-PK-1334800000-SP	A.71
1346480000	UR20-PK-1334740000-SP	A.71
1346490000	UR20-PK-1334790000-SP	A.71
1346500000	UR20-PK-1315550000-SP	A.71
1346510000	UR20-PK-1315770000-SP	A.71
1346520000	UR20-PK-1315570000-SP	A.71
1346540000	UR20-PK-1315690000-SP	A.71
1346550000	UR20-PK-1315610000-SP	A.71
1346560000	UR20-PK-1335030000-SP	A.71
1346570000	UR20-PK-1335050000-SP	A.71
1346590000	UR20-PK-1315210000-SP	A.71

Order No.	Type	Page
-----------	------	------

1346610000	UR20-EBK-ACC	A.69
1346640000	UR20-EM-1315170000-SP	A.71
1346650000	UR20-EM-1315080000-SP	A.71
1346670000	UR20-EM-1315190000-SP	A.71
1346680000	UR20-EM-1315200000-SP	A.71
1346690000	UR20-EM-1315210000-SP	A.71
1346700000	UR20-EM-1315220000-SP	A.71
1346710000	UR20-EM-1315230000-SP	A.71
1346720000	UR20-EM-1315240000-SP	A.71
1346730000	UR20-EM-1315250000-SP	A.71
1346740000	UR20-EM-1315270000-SP	A.71
1347120000	UR20-EM-1315540000-SP	A.71
1347130000	UR20-EM-1315550000-SP	A.71
1347140000	UR20-EM-1315570000-SP	A.71
1347150000	UR20-EM-1315590000-SP	A.71
1347180000	UR20-EM-1315600000-SP	A.71
1347190000	UR20-EM-1315610000-SP	A.71
1347200000	UR20-EM-1315620000-SP	A.71
1347250000	UR20-EM-1315670000-SP	A.71
1347270000	UR20-EM-1315680000-SP	A.71
1347280000	UR20-EM-1315690000-SP	A.71
1347290000	UR20-EM-1315700000-SP	A.71
1347330000	UR20-EM-1315730000-SP	A.71
1347370000	UR20-EM-1334710000-SP	A.71
1347370000	UR20-EM-1315770000-SP	A.71
1347420000	UR20-EM-1334740000-SP	A.71
1347450000	UR20-EM-1334770000-SP	A.71
1347470000	UR20-EM-1334780000-SP	A.71
1347480000	UR20-EM-1334790000-SP	A.71
1347490000	UR20-EM-1334800000-SP	A.71
1347500000	UR20-EM-1334810000-SP	A.71
1347520000	UR20-EM-1335030000-SP	A.71
1347530000	UR20-EM-1335040000-SP	A.71
1347540000	UR20-EM-1335050000-SP	A.71

135000000

1350930000	UR20-BM-SP	A.71
1350940000	UR20-BM-PF-I-SP	A.71
1350950000	UR20-BM-PF-O-SP	A.71
1350970000	UR20-BM-SIL-SP	A.71

136000000

1361520000	UR20-PK-1334870000-SP	A.71
------------	-----------------------	------

139000000

1394390000	UR20-4AHUI-12	A.49
1394400000	UR20-8DI-P-3W	A.19
1394420000	UR20-4DD-PN-2A	A.29

141000000

1411430000	UR20-PK-1394400000-SP	A.71
------------	-----------------------	------

142000000

1429420000	THM UR20 WS	A.69
1429430000	ESO UR20 DIN A4 WS	A.69
1429910000	THM UR20 GE	A.69

143000000

1434220000	UR20-EM-1394400000-SP	A.71
1434230000	UR20-EM-1394390000-SP	A.71
1435740000	UR20-EM-1315710000-SP	A.71

146000000

1460140000	UR20-2DI-P-TS	A.23
1460150000	UR20-4DI-P-TS	A.24
1463680000	UR20-EM-1460150000-SP	A.71
1463690000	UR20-EM-1460140000-SP	A.71
1469340000	UR20-PGO.35	A.20

147000000

1475030150	SAIL-URZM12G-C-1.5U	B.35
1475040150	SAIL-URZM12W-C-1.5U	B.35
1475050150	SAIL-URZM8G-3-1.5U	B.35
1475060150	SAIL-URZM8W-3-1.5U	B.35
1475070150	SAIL-URPM12G-C-1.5U	B.35
1475080150	SAIL-URPM12W-C-1.5U	B.35
1475090150	SAIL-URPM12G-O-1.5U	B.35
1475120150	SAIL-URPM12W-O-1.5U	B.35
1475130150	SAIL-URPM12G-4-1.5U	B.35
1475140150	SAIL-URPM12W-4-1.5U	B.35
1475160150	SAIL-URPM8G-3-1.5U	B.35
1475170150	SAIL-URPM8W-3-1.5U	B.35
1475280000	SAIL-URPM12G-C-1.5V	B.35
1475290000	SAIL-URPM12W-C-1.5V	B.35
1475300000	SAIL-URPM12G-O-1.5V	B.35
1475310000	SAIL-URPM12W-O-1.5V	B.35
1475320000	SAIL-URPM12G-4-1.5V	B.35
1475330000	SAIL-URPM12W-4-1.5V	B.35
1475340000	SAIL-URPM8G-3-1.5V	B.35
1475350000	SAIL-URPM8W-3-1.5V	B.35
1475450150	SAIL-URPM12W-2L-1.5U	B.35

Order No.	Type	Page
-----------	------	------

1475470150	SAIL-URPM8W-2L-1.5U	B.35
1475500150	SAIL-URPM12W-2L-1.5V	B.35
1475510150	SAIL-URPM8W-2L-1.5V	B.35

148000000

1480950000	UR20-EM-1394420000-SP	A.71
1483050000	KOSM BHZ.00	A.69
1483940000	UR20-PK-1315270000-SP	A.71
1483950000	UR20-PK-1315670000-SP	A.71
1483960000	UR20-PK-1315220000-SP	A.71
1483970000	UR20-PK-1315230000-SP	A.71
1483980000	UR20-PK-1394420000-SP	A.71
1483990000	UR20-PK-1315250000-SP	A.71
1484000000	UR20-PK-1315640000-SP	A.71
1484010000	UR20-PK-1315600000-SP	A.71
1484020000	UR20-PK-1315620000-SP	A.71
1484030000	UR20-PK-1394390000-SP	A.71
1484040000	UR20-PK-1315700000-SP	A.71
1484050000	UR20-PK-1315710000-SP	A.71
1484070000	UR20-PK-1315680000-SP	A.71
1484080000	UR20-PK-1334780000-SP	A.71
1484090000	UR20-PK-1334810000-SP	A.71
1484100000	UR20-PK-1335040000-SP	A.71
1484110000	UR20-PK-1460140000-SP	A.71
1484120000	UR20-PK-1334880000-SP	A.71
1484130000	UR20-PK-1334930000-SP	A.71
1484430000	UR20-PK-1460150000-SP	A.71
1484440000	UR20-PK-1334910000-SP	A.71

150000000

1506910000	UR20-4AI-UI-16-DIAG-HD	A.48
1506920000	UR20-4AI-UI-16-HD	A.47
1508080000	UR20-2FCNT-100	A.39

151000000

1515420000	UR20-EM-1506920000-SP	A.71
1515430000	UR20-EM-1506910000-SP	A.71
1515440000	UR20-EM-1508080000-SP	A.71
1515800000	UR20-PK-1315190000-SP	A.71
1518820000	UR20-PK-1506910000-SP	A.71
1518830000	UR20-PK-1506920000-SP	A.71
1518840000	UR20-PK-1508080000-SP	A.71
1518870000	UR20-PK-1315690000-SP	A.71
1518880000	UR20-PK-1315730000-SP	A.71

178000000

1781520000	SAI-SK Stecker M12	B.12
1784770000	SAIEND CAN-M12 5P A-COD	B.16
1784770000	SAIEND PB M12 4P B-COD	B.12

180000000

Addresses worldwide

Let's connect.

AE United Arab Emirates

Weidmüller Middle East FZE
Warehouse Q3-79
SAIF-Zone
P.O. BOX 8591
Sharjah
Tel +971 65572723
Fax +971 65572724
wme.info@weidmueller.com

AO Angola

Please contact
Phambili Interface (Pty) Ltd.
South Africa

AR Argentina

CPI SA
Bauness 2660
C1431DOF Buenos Aires
Tel +54 11 4523 8008
Fax +54 11 4522 0546
info@cpi.com.ar
www.cpi.com.ar

AT Austria

Weidmüller GmbH
IZ NOE Süd Straße 2b, Obj
M 59
2355 Wiener Neudorf
Tel +43 2236 67080
Fax +43 2236 6708-899
office.at@weidmueller.com
www.weidmueller.com

AU Australia

Weidmüller Pty. Ltd.
PO BOX 6944
Huntingwood 2148
Huntingwood Drive 43
Huntingwood NSW 2148
Tel +61 2 9671 9999
Fax +61 2 9671 9911
info@weidmuller.com.au
www.weidmuller.com.au

AZ Azerbaijan

Representative Office
Rashad Mahmudov
Demirchi Tower, 4th floor
37, Khojali ave.
AZ 1025 Baku
Tel +994 12 488 80 36
Fax +994 12 488 80 37
rashad.mahmudov@
weidmueller.com

BA Bosnia and Herzegovina

Please contact
our Representative Office
Weidmüller Interface GmbH
& Co. KG
Serbia

or

BIG electric d.o.o
Mladena Stojanovića 117A
78000 Banja Luka
Tel +387 5 1926277
Fax +387 5 1926277
bigelectric@blic.net
www.bigelectric.ba

BE Belgium

Weidmüller Benelux B. V.
Mechelsesteenweg 519 bus
6 en 7
1930 Nossage
Tel +32 2 752 40 70
Fax +32 2 751 36 06
info@weidmueller.be
www.weidmueller.be

BG Bulgaria

Weid-Bul EOOD
Bul. „Kliment Ohridski“ 13
1756 Sofia
Tel +359 2 963 2560
Fax +359 2 963 1098
sofia@weidbul.com
www.weidbul.com

BH Bahrain

Khayber Trading Company
P.O. Box 1976
Manama
Tel +973 720747
Fax +973 720331
khayber@batelco.com.bh

BR Brazil

Weidmüller Conexel do Brasil
Conexes Elétricas Ltda.
R. Garcia Lorca, 176 - V.
Paulicéia
São Bernardo do Campo,
São Paulo
09695-900
Tel +55 (11) 4366-9600
Fax +55 (11) 4362-1677
vendas@weidmueller.com.br
www.weidmueller.com.br

BW Botswana

Please contact
Phambili Interface (Pty) Ltd.
South Africa

BY Belarus

TECHNIKON Ltd.
Nezavisimosti pr. 177-9
220125 Minsk
Tel +375 17 393-11-77
Fax +375 17 3930080
wm@technikon.by

CA Canada

W Interconnections Canada
Inc.
10 Spy Court
Markham Ontario L3R 5H6
Tel +1 (905) 475-1507 Ext.
9836
Fax +1 (905) 475-2798
support@weidmuller.ca
www.weidmuller.ca

CG Congo

Please contact
Phambili Interface (Pty) Ltd.
South Africa

CH Switzerland

Weidmüller Schweiz AG
Rundbuckstraße 2
8212 Neuhausen am
Rheinfall SH
Tel +41 52 674 07 07
Fax +41 52 674 07 08
info@weidmueller.ch
www.weidmueller.ch

CL Chile

ATS - INTECH
Maria Luisa Santander 0475
Santiago
Providencia 7500859
Tel +56 2 341 1271
Fax +56 2 341 1275
felipe@atsintech.com
www.atsintech.com

CPI CHILE LTDA
Av. Presidente Frei Montalva
6001, 47 complejo el cortijo
Santiago - Conchalí
Tel +562 963 8440
Fax +562 963 8440
cpi@cpichile.cl
www.cpichile.cl

CN China

Weidmüller Interface
(Shanghai) Co. Ltd.
100 Yutong Road
25 F, BM Intercontinental
Business Center
200070 Shanghai
Tel +86 21-22195008
Fax +86 21-22195009
customer.hotline@
weidmuller.com.cn
www.cnweidmuller.com

CO Colombia

Automatización Avanzada
S. A.
Carrera 97 No., 24 c - 23
Bodega 4
110911 Bogotá-D.C.
Tel +57 (1) 547-8510
Fax +57 (1) 422-3044
comercial@
automatizacionavanzada.com
www.
automatizacionavanzada.com

CR Costa Rica

ELVATRON S. A.
la Uruca 400 Norte Banco
Costa Rica
San Jose Costa Rica
Tel +506 2561-060
Fax +506 5200-909
dirk.haese@elvatron.com
www.elvatron.com

CZ Czech Republic

Weidmüller s.r.o.
Lomnického 5/1705
140 00 Praha 4
Tel +420 244 001 400
Fax +420 244 001 499
office@weidmueller.cz
www.weidmueller.cz

DE Germany

Weidmüller GmbH & Co. KG
Ohmstraße 9
32758 Detmold
Postfach 30 54
32720 Detmold
Tel +49 5231 1428-0
Fax +49 5231 1428-116
weidmueller@weidmueller.de
www.weidmueller.de

DK Denmark

Weidmüller Danmark
Vallensbækvej 18A
2605 Brøndby
Tel +45 27747800
kundenservice@weidmuller.dk
www.weidmuller.dk

EC Ecuador

Elystec S. A., Electricidad
Sistemas y Tecnología
Vasco de Contreras N35-251
y Mañosa
Quito - Pichincha
Tel +593 22456510
Fax +593 22456755
Elystec@uio.satnet.net

EE Estonia

Please contact
our Representative Office
Weidmüller Interface GmbH
& Co. KG
Latvia

or

Soots Interface OÜ
Pärnu mnt 142
11317 Tallinn
Tel +372 609 6933
Fax +372 609 6933
info@sootsinterface.ee
www.sootsinterface.ee

EG Egypt

Standard Electric (OMEGA)
87, Mohamed Farid Street
Heliopolis
Cairo
Tel +20 2 642 2977
Fax +20 2 642 2955
stdelec@rite.com

ES Spain

Weidmüller, S. A.
Narcis Monturiol 11-13, Pol.
Ind. Sudoste
08960 Sant Just
Desvern - Barcelona
Tel +34 934 803 386
Fax +34 933 718 055
weidmuller@weidmuller.es
www.weidmuller.es

FI Finland

Weidmüller Aktiebolaget
Weidmüller Aktiebolagetin
sivillike
Koy Plaza Vivace
Ayritie 8C
FI 01510 Vantaa
Tel +358 20 7351300
Fax +358 800 114 667
asiakaspalvelu@weidmuller.fi
www.weidmuller.fi

FR France

Weidmüller E. U. R. L.
12, Chaussée Jules César
BP 263 Osny
95523 Cergy-Pontoise Cedex
Tel +33 1 34 24 55 00
Fax +33 1 34 24 55 01
mail@weidmuller.fr

GB Great Britain

Weidmüller Ltd.
Klippon House
Centurion Court Office Park,
Meridian East, Meridian
Business Park
Leicester
LE19 1TP
Tel +44 116 282 3470
Fax +44 116 289 3582
marketing@weidmuller.co.uk
www.weidmuller.co.uk

GE Georgia

Please contact
our Representative Office
Rashad Mahmudov
Azerbaijan.

GR Greece

G.A. Solutions
Ippokratous 11 Metamorfosi
144 52 Athen
Tel +30 210 2823233
Fax +30 210 2823233
info@weidmuller.gr
www.weidmuller.gr

GT Guatemala

Prestelectro, Prestegard
No. 10 Metropolis Drive,
Avenida Petapa 44-22,
Zona 12
Guatemala City
Tel +502 2442-3346
Fax +502 2476-8945
ventas@prestelectro.com

HK Hong Kong

Weidmüller (Hong Kong)
Limited Co. Ltd.
Unit 1617, Metropolis Tower
No. 10 Metropolis Drive,
Hungghom, Kowloon
Tel +852 3154 8088
Fax +852 31548099
Info-hk@weidmueller.com.hk

HR Croatia

ElektroPARTNER d.o.o.
Slavonska avenija 24/6
HR-10000 Zagreb
Tel +385 (1) 6184 793
Fax +385 (1) 6184 795
elektropartner@zg.t-com.hr
www.elektropartner.hr

HU Hungary

Weidmüller Kereskedelmi Kft.
Budapest
Gubacsi út 6.
1097
Tel +36 1 382 7700
Fax +36 1 382 7701
info@weidmueller.hu
www.weidmueller.hu

ID Indonesia

PT. Nego Electrindo
Ruko Mega Grosir Cempaka
Mas Blok II No. 22
Jakarta 10640
Tel +62 21 42882255
Fax +62 21 42882266
sales@negoelectrindo.co.id

IE Ireland

Please contact
Weidmüller Ltd.
Great Britain

IL Israel

A. U. Shay Ltd.
23/25, Embar Street
49222 Petach-Tikva
P.O. Box 1 00 49
49222 Petach-Tikva
Tel +972 3-923-3601
Fax +972 3-923-4601
shay@uriel-shay.com
www.uriel-shay.com

ATEKA Ltd.
4, Ha Tavor lane Industrial
area Segula
49691 Petach-Tikva
P.O. Box 4710
Petach-Tikva
Tel +972 73-200-1311
Fax +972 3-924 4245
marketing@ateka.co.il
www.ateka.co.il

IN India

Representative Office
Weidmüller Electronics India
Pvt. Ltd.
12th Lane North Avenue, Opp
Joggers Park,
Kalyani Nagar, Pune
411 006
Tel +91 20-41290090
Ntish.Rajan@weidmueller.de
www.weidmueller.com

IS Iceland

Samey Automation Center
Lyngas 13
210 Garobær
Tel +354 510 5200
Fax +354 5 10 5201
Samey@samey.is
www.samey.is

IT Italy

Weidmüller S. r.l.
Via Albert Einstein 4
20092 Cinisello
Balsamo Milano
Tel +39 02 660681
Fax +39 02 6124945
weidmuller@weidmuller.it
www.weidmuller.it

JM Jamaica

Please contact
W Interconnections Inc.
United States

JO Jordan

Trans Jordan for Electro
PO Box 33 06 07
Amman
Tel +962 6 533 2020
Fax +962 6 533 5800
transjordan@batelco.jo

JP Japan

Nihon Weidmüller Co. Ltd.
Sphere Tower Tennoz 2-2-8
Higashi-Shinagawa,
Shinagawa-ku
Tokyo
140-0002
Tel +81 3 6711 5300
Fax +81 3 6711 5333
weidmullerjapan@weidmuller.
co.jp
www.weidmuller.co.jp

KE Kenya

Please contact
Phambili Interface (Pty) Ltd.
South Africa

KR Korea

Weidmüller Korea Co. Ltd.
9th floor, Wvongbang B/D
Samsong 2-Dong, Gangnam-Gu
Seoul 143-42
Tel +82 2-516-0003
Fax +82 2-516-0090
info@weidmuller.co.kr
www.weidmuller.co.kr

KZ Kazakhstan

Please contact
OOO Weidmüller
Russia

LT Lithuania

Please contact
our Representative Office
Weidmüller Interface GmbH
& Co. KG
Latvia

or

ELEKTROS IRANGA
Tinklu g. 29 a
LT-5319 Panevezys
Tel +370 (45) 582 828
Fax +370 (45) 582 727
info@eliranga.lt

LU Luxembourg

Please contact
Weidmüller Benelux B. V.
Netherlands

LV Latvia

SIA Abi4
Daugavgrivas 31b
Riga, LV-1007
Tel +371 674 70999
Fax +371 674 65637
abi_4@tvnet.lv

Representative Office
Weidmüller Interface GmbH
& Co. KG
Udens str. 12-118
Riga, LV-1007
Tel +371 29254766
Fax +371 676 24562
Ilgonis.rudaks@weidmuller.
com
www.weidmuller.com



MD Moldova

BERHORD A & D srl
79/1, str. Milescu Spartaru
MD-2075 Chisinau
Moldova
Tel +373 (22) 815002
Fax +373 (22) 815007
atiuleanu@berhord.com
www.ad.berhord.com



You can find all Weidmüller addresses and your local contact on the internet at: www.weidmuller.com/countries

Let's connect.

Sales company 
Representation abroad 
without representation abroad 

- ME Montenegro**
Please contact our Representative Office Weidmüller Interface GmbH & Co. KG Serbia.
- MG Madagascar**
Please contact Phambili Interface (Pty) Ltd. South Africa
- MK Macedonia**
Please contact our Representative Office Weidmüller Interface GmbH & Co. KG Serbia
or
ELEKTRO - SMK dool
UL. III Makedonska brigada b.b.
1000 Skopje
Tel +389 22460295
Fax +389 22460298
Elektro-smk@telekabel.net.mk
- MT Malta**
E. S. S., Electrical Supplies & Services Ltd.
104 J. Sciberras Str.
Hamrun
HMR 08
Tel +356 21255777
Fax +356 21255999
robert@ess.com.mt
- MU Mauritius**
Mubelo Electrical Ltd.
Office 25, Gateway building,
St Jean Road
Quatre Bornes
Mauritius
Tel +230 4670989
Fax +230 4654051
richard.mubelo@orange.mu
- MW Malawi**
Please contact Phambili Interface (Pty) Ltd. South Africa
- MX Mexico**
W Interconnections S. A.
DE C. V.
Blvd. Hermanos Sardan 698,
Col. San Rafael Oriente
72029 Puebla
Tel +52 (222) 268 6227
Fax +52 (222) 286 6242
clientes@weidmuller.com.mx
- MY Malaysia**
Connect Plus Technology Sdn Bhd
No. 43, Jalan PJS 11/22,
Bandar Sunway
48150 Petaling Jaya
Selangor Darul Ehsan
Tel +60 3 5633 7363
Fax +60 3 5633 6562
paul@cpotech.com.my
- MZ Mozambique**
Please contact Phambili Interface (Pty) Ltd. South Africa
- NA Namibia**
Please contact Phambili Interface (Pty) Ltd. South Africa
- NG Nigeria**
Please contact Phambili Interface (Pty) Ltd. South Africa
- NL Netherlands**
Weidmüller Benelux B. V.
Franciscusweg 221
1216 SE Hilversum
P.O. Box 1505
1200 BM Hilversum
Tel +31 35 626 12 61
Fax +31 35 623 20 44
info@weidmuller.nl
www.weidmuller.nl
- NO Norway**
Sivilingeniør J.F. Knudtzen AS
Billingsstadsletta 97
1396 Billingstad
PO Box 160
1378 Nesbru
Tel +47 66 98 33 50
Fax +47 66 98 09 55
firmapost@jfknudtzen.no
www.jfknudtzen.no
- NZ New Zealand**
Cuthbert S. Steward Ltd.
27 Te Puni Street
Petone
PO Box 38496
Wellington Mail Centre 5054
Tel (04) 568 6156
Fax (04) 568 6056
csi@cuthbertsteward.co.nz
Cuthbert S. Steward Ltd
4 Fred Thomas Drive
Acon Building, Ground Floor,
South Entry
Takapuna
PO Box 100 338
North Shore City 0745
Tel (09) 489 1751
Fax (09) 489 1752
csiak@cuthbertsteward.co.nz
- OM Oman**
DAN INTERNATIONAL LLC.
Ghaia St. 111
BP 2901
Seeb
Tel +968 5036 77
Fax +968 5037 55
yedu@danintl.com
- PE Peru**
IMPEXINCA S.A.C.
Calle Ortiz de Zavallos No.
105, Urb. San Antonio
18
Lima, Miraflores
Tel +51 1 447 5608
info@impexinca.pe
www.impexinca.pe
J & W CIA. S. A.
Calle 6 Mz. D Lte. 23, Urb.
Ind. Grimanesa
01
Callao
Tel +51 1 572 2539
Fax +51 1 572 0152
contacto@jwcia.com
www.jwcia.com
- PH Philippines**
Enclosure Systems Specialists Inc.
2276 Don Chino Roces
Avenue Extension
Room 103/105 Narra Building
1231 Makati City
Tel +63 2 813 8580
Fax +63 2 813 8596
sales_encsys@pltdsl.net
www.enclosuresystemspsh.com
- PK Pakistan**
Kana Controls (Pak)
Apartment No. 33 C III,
Chenab Block, Allama Iqbal
Town
Lahore
Tel +92 42 5419948
Fax +92 42 5422895
nadaem@kanapak.com
www.kanapak.com
- PL Poland**
Weidmüller Sp. z o. o.
ul. Ogrodowa 58
00-876 Warszawa
Tel +48 22 510 09 40
Fax +48 22 510 09 41
biuro@weidmuller.com.pl
www.weidmuller.pl
- PR Puerto Rico**
Please contact W Interconnections Inc. United States
- PT Portugal**
Weidmüller Sistemas de Interface S. A.
Estrada Outeiro Polima, R.
Augusto Dias da Silva, Lote B - Esc. 2
São Domingos de Rana
2785-515 Abóboda
Tel +351 214 459 191
Fax +351 214 455 871
weidmuller@weidmuller.pt
www.weidmuller.pt
- PY Paraguay**
Please contact CPI SA Argentina
- RO Romania**
Representative Office Weidmüller Interface GmbH & Co. KG Ionescu Crum Street, No. 1, 1st Tower, 1st Floor, Office 4
500446 Brasov - Brasov Business Park
Tel +40 (268) 446 222
Fax +40 (268) 446 224
claudiu.totea@weidmuller.com
www.weidmuller.com
- RS Serbia**
Representative Office Weidmüller Interface GmbH & Co. KG Ustanicka 189, III sprat lokal 7a
11050 Beograd
Tel +381 11285274
Fax +381 112885274
zoran.rabrenovic@weidmuller.com
- RU Russia**
OOO Weidmüller
Warshavskoye highway, 25
A, bld. 6
Moskau
117105
Tel +7 (495) 771-69-40
Fax +7 (495) 771-69-41
Info@weidmuller.ru
www.weidmuller.ru
- SA Saudi Arabia**
Please contact Weidmüller Middle East FZE United Arab Emirates
- SE Sweden**
Weidmüller AB
Axel Danielssons väg 271
BOX 31025
SE-200 49 Malmö
Tel +46 77-143 00 44
Fax +46 40-37 48 60
info@weidmuller.se
www.weidmuller.se
- SG Singapore**
Weidmüller Pte. Ltd.
70 Bendemeer Road
04-03 Luzerne Building
Singapore 339940
Tel +65 6841 5311
Fax +65 6841 5377
info@weidmuller.com.sg
www.weidmuller.com.sg
- SI Slovenia**
Elektrospoj d. o. o.
Stegre 25
SI- 1000 Ljubljana
Osrednjejslovenska
Tel +386 1 511 3810
Fax +386 1 511 1604
info@elektrospoji.si
www.elektrospoji.si
- SK Slovakia**
ELEKTRIS s.r.o.
Elektrárenská 1
831 04 Bratislava
Tel +421 2/4920 0113
Fax +421 2/4920 0119
bratislava@elektris.sk
- SV El Salvador**
Prestegard Electro
11 Avenida Norte No. 240
Edificio Salazar No. 2
San Salvador
Tel +503 2271 1690
Fax +503 2221 3851
prestegard@navegante.com.sv
- SY Syria**
Please contact Weidmüller Middle East FZE United Arab Emirates
- SZ Swaziland**
Please contact Phambili Interface (Pty) Ltd. South Africa
- TH Thailand**
Pisanu Engineering Co. Ltd.
Kwang Dingaeng, Khet Dingaeng
800/2 Soi Trakulsuk, Asoke-dindaeng Road
Dindaeng, Bangkok 10400
Tel +66 2 248 2896
Fax +66 2 642 9220
ecsales@pisanu.co.th
www.pisanu.co.th
Representative Office Weidmüller Pte. Ltd.
37/F, Sathorn Square Building
98 North Sathorn Road
Bangkok, Silom Bangrak 10500
Tel +66 2 105 6300
Fax +662 105 6301
info@weidmuller.com.sg
- TN Tunisia**
Please contact Weidmüller E. U. R. L. France
- TR Turkey**
Weidmüller Elektronik Ticaret Ltd. Sirketi
Kavacik Mah. Orhan Veli Kanik Caddesi 9/1
34810 Beykoz / Istanbul
Tel +90 (216) 537 10 70
Fax +90 (216) 537 10 77
info@weidmuller.com.tr
www.weidmuller.com.tr
- TW Taiwan**
Weidmüller (Hong Kong) Limited
No. 3, Lane 89, ChungYang N. Rd
24148 SanChuang City, Taipei
Tel +886 921 949 751
roy.lin@weidmuller.com.hk
- TZ Tanzania**
Please contact Phambili Interface (Pty) Ltd. South Africa
- UA Ukraine**
LLC WM UKRAINE
Levaneskogo str. 6
Kiev
03058
Tel +38 044 490 32 48
Fax +38 044 490 32 49
info@wm-ua.com.ua
wm-ua.com.ua/
TEKO INTERFACE
Lomonosova Str. 73 g
Kiev
03022
Tel +380 (44) 374 06 40
Fax +380 (44) 374 06 42
weidmuller@tekointerface.com
www.tekointerface.com.ua
- US United States**
W Interconnections Inc.
821 Southlake Boulevard
Richmond Virginia 23236
Tel +1 (804) 794-2877
Fax +1 (804) 379-2593
info@weidmuller.com
www.weidmuller.com
- UZ Republic of Uzbekistan**
Please contact OOO Weidmüller Russia
- VN Vietnam**
AUMI Industrial Equipment & Automation Company Limited
E1, La Thanh Hotel
218 Doi Can Street
Lieu Giai Ward, Ba Dinh District
Hanoi City
Tel +84 4 37628601
Fax +84 4 62661391
aumi@aumi.com.vn
www.aumi.com.vn
Representative Office Weidmüller Pte. Ltd.
Level 16 Saigon Tower Building
29 Le Duan Street
District 1
Ho Chi Minh
Tel +848 3520 7717
Fax +848 3520 7604
info@weidmuller.com.sg
- ZA South Africa**
Phambili Interface (Pty) Ltd.
PO Box 193
1609 Johannesburg, Edenvale
5 Bundo Road, Sebenza
1610 Johannesburg
Tel +27 (11) 4521930
Fax +27 (11) 4526455
info@weidmuller.co.za
www.weidmuller.co.za
- ZM Zambia**
Please contact Phambili Interface (Pty) Ltd. South Africa
- ZW Zimbabwe**
Please contact Phambili Interface (Pty) Ltd. South Africa

We cannot guarantee that there are no mistakes in the publications or software provided by us to the customer for the purpose of making orders. We try our best to quickly correct errors in our printed media.

X

All orders are based on our general terms of delivery, which can be reviewed on the websites of our group companies where you place your order. On demand we can also send the general terms of delivery to you.